



Proposal

4601 Commercial Avenue Marion, IA 52302 319.373.1425

Proposal Submitted To: New Hampton Community Schools	Date May 15, 2019	
Street 701 West Main St	Job Name New High School Gym Sound System	
City State Zip Code New Hampton, Iowa	Job Location High School	
Contact Supt Jay Jurrens	Proposal # 19135ma	Phone 712-260-1082

After a complete review of the drawings and computer aided design we are pleased to present a design build proposal for a new sound system. We have designed this system to support all types of functions from graduation to all types of sporting events. During graduation with a stage set we will time align the loudspeakers for a frontal presentation and during most sport events a simple sport mode will be used with a high power distributed system design. All bleacher and floor areas will be provided full fidelity audio coverage. We will also provide and install a dual subwoofer loudspeaker to extend the music range for all music playback. This option can be removed if you wish and we can provide a cost savings if you wish.

The new system electronics will be installed in a locked equipment cabinet and all system control will be provided from a simple wall mounted keypad which can be installed at a location of your choice. It will also be installed under a Lexan cover for protection since this space is a gymnasium.

Our package will include a handheld wireless microphone, a new miniature podium microphone, two new wired handheld microphones with stands, a headset sports mic with talk box and a wireless media streamer for all types of music playback. The streamer will allow music from phones or tablets to play over the system.

Once everything has been installed we will properly calibrate the system and follow that with owner training.

All equipment will be as shown on the attached equipment list and specification sheets.

We propose hereby to furnish material and labor complete in accordance with above specifications, for the sum of:

Thirty Seven Thousand Three Hundred Sixty-Five Dollars dollars **\$37,365.00**

Payment to be made as follows: plus tax

35% Deposit, Balance Due Upon Completion.

All material is guaranteed to be as specified. All work to be completed in a workmanlike manner according to standard practices. Any alteration or deviation from above specifications involving extra costs will be executed only upon written orders, and will become an extra charge over and above the estimate. All agreements contingent upon strikes, accidents or delays beyond our control. Owner to carry fire, tornado and other necessary insurance. Our workers are fully covered by Workmen's Compensation insurance.

Authorized Signature

Mark A. Doubet

Note: This proposal may be withdrawn by us if not accepted within **30** days.

Acceptance of Proposal - The above prices, specifications and conditions are satisfactory and are hereby accepted. You are authorized to do the work as specified. Payment will be made as outlined above.

Signature

Date of Acceptance:

New Hampton High School

Gymnasium Sound System

Equipment

Part Number	Product Description / Model Number	Quantity	Vendor
R.35-3896W	Full Range Loudspeakers	9	Community
V2-212SW	Dual 12" Subwoofer	1	Community
CMX2000Va	Main Loudspeaker Power Amplifiers	2	QSC
GX5	Subwoofer Power Amplifier	1	QSC
Tesira FORTE A1	Digital Processor	1	Biamp
Tesira TEC-1S	Keypad Control	1	Biamp
SX1115RT	Power Controller	1	Surgex
GS108P	POE Switch	1	Netgear
DN-300BR	Bluetooth Receiver	1	Denon
SM35-XLR	Announcer's Headset Microphone	1	Shure
SAS1	Announcer's Switch	1	Rapco
MX418s/s	Podium Microphone	1	Shure
SM58cn	Microphone	2	Shure
AQ25	Microphone Cable	2	Rapco
MC40-B Pro	Microphone Stand	2	Ultimate
ERK-2725 Config	Floor Rack with Door	1	Middle Atlantic
UD4	Storage Drawer for mics and cables	1	Middle Atlantic
K3FS	Microphone Input Plates	4	Rapco
22/2s	Cable	800	Liberty
14/2	Cable	2,000	Liberty
CAT5E	Cable	200	Liberty
LSR	Loudspeaker Rigging	1	DBA
BLX24R/B58	Handheld Wireless Microphone System	1	Shure
Lot	Blanks	1	Middle Atlantic
	Tuning and Training	1	DBA
R.35 COAX	Full Range Loudspeakers Floor Coverage	8	Community

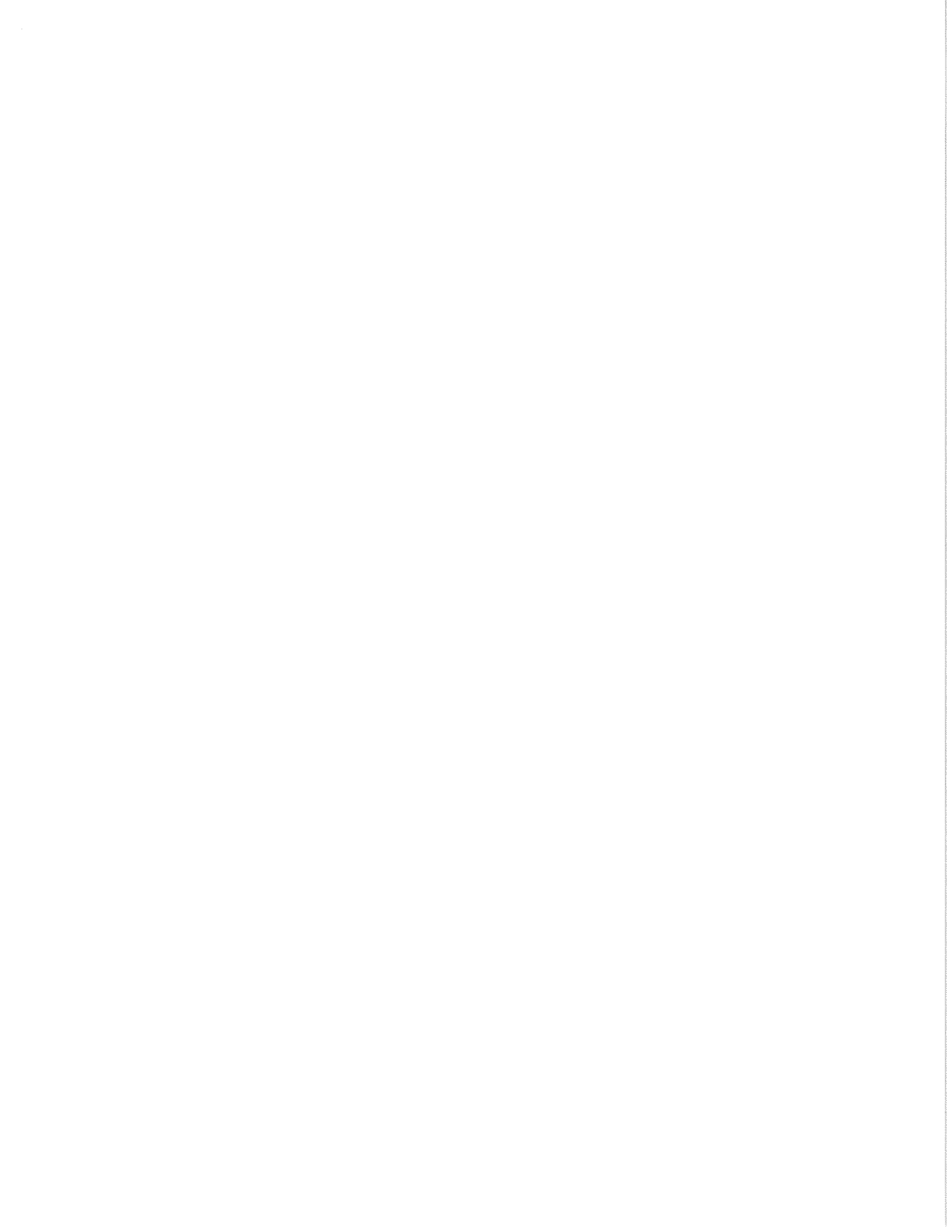

R SERIES
 Point Source

R.35-3896

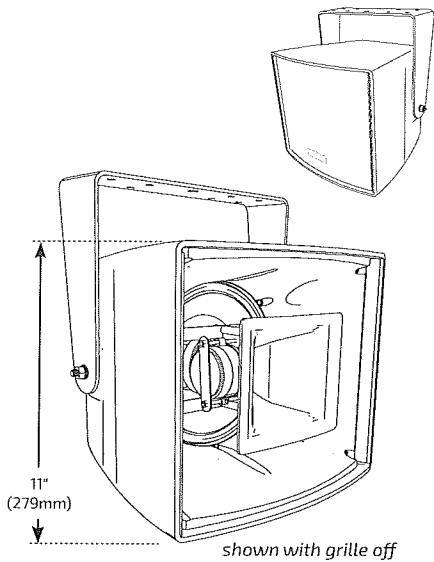
 THREE-WAY FULL-RANGE (90° x 60°)
 WEATHER-RESISTANT LOUDSPEAKER

FEATURES

- Excellent musicality and intelligibility, and low distortion in an extremely compact enclosure
- Weather-resistant, compact, matte finish paintable high impact ABS plastic modified-trapezoidal enclosure
- Hydrophobically-treated grille and LF driver cone, polymer HF and MR diaphragm, moisture-sealed crossover
- 200W Autoformer (standard), selectable 8 ohm or 70V/100V operation
- Corrosion-resistant dual-layer powder-coated low-profile steel yoke and aluminum grille

TECHNICAL SPECIFICATIONS¹

Operating Mode	Passive, Selectable Low Impedance or 70V/100V				
Operating Environment	Indoor or Weather-Resistant Outdoor				
Operating Range²	80 Hz to 16 kHz				
Nominal Beamwidth (H x V)	90° x 60°				
Transducers	LF 1 x 8" (203mm) Carbon ring cone with hydrophobic treatment, 3" (76mm) Voice Coil MR 2 x 2.35" (60mm) MultiSource Waveguide™ compression drivers HF 1 x 1" (25mm) exit polymer diaphragm compression driver				
Continuous Power Handling³ @ Nominal Impedance	Passive	56V	400W @ 8 Ohms (1600W peak)		
Autoformer Taps	70V: 200W, 100W, 50W, 25W 100V: 200W, 100W, 50W				
		MUSIC		VOICE	
Nominal Sensitivity⁴	Passive	@ 1W 98dB	@ 2.83V 98 dB	@ 1W 100 dB	@ 2.83V 100 dB
Nominal Maximum SPL⁵ (Whole Space)	Passive	Peak 130 dB	Continuous 124 dB	Peak 132 dB	Continuous 126 dB
Equalized Sensitivity⁶	System	@ 1W 97 dB	@ 2.83V 97 dB		
Equalized Maximum SPL⁷	System	Peak 129 dB	Continuous 123 dB		
Required Accessories	High Pass Filter - 80 Hz, 24 dB /octave, Digital Signal Processor				
Recommended Amplifiers	400W - 800W @ 8 Ohms, (56V - 80V)				

APPLICATIONS

Theme and Amusement Parks · Malls · Stadiums
 Fairgrounds · Outdoor Entertainment Centers
 Race Tracks · Athletic Fields · Swimming Pools
 Background Music / Voice Paging Systems
 Convention Centers · Factories
 Multipurpose outdoor and indoor venues

DESCRIPTION

The R.35-3896 is a fully horn-loaded triaxial three-way, full-range loudspeaker system designed to provide high quality voice and music reproduction in applications requiring extreme weather resistance. It is designed to withstand long-term exposure to tough, environmental conditions and to provide musical performance normally only associated with indoor loudspeakers. The R.35-3896 features Community's innovative MultiSource Waveguide™ horn design; the output from the dual midrange compression drivers and 1-inch exit HF driver are combined seamlessly into a single time-coherent source, resulting in excellent musicality, intelligibility and dispersion consistency. The high output, 3-inch voice coil, 8-inch carbon ring cone LF driver features a flange-less woofer basket design that permits a cone area nearly equivalent to a typical 10-inch driver, resulting in high sensitivity and increased LF extension. The low LF/MR passive crossover point results in improved mid-range pattern control and elimination of horn coloration in the LF response.

The Music/Voice switch allows for additional application flexibility. The "Music" setting provides an out-of-the-box flat response and selecting "Voice" provides up to a 5dB boost for increased vocal projection and intelligibility. The LF cone is treated with the same hydrophobic coating as the grille cloth to ensure trouble-free performance in the harshest conditions. The R.35-3896 carries a 5 year product warranty and a 15 year enclosure warranty.

PHYSICAL

Input Connection	NL4 Speakon-type connector (low impedance only), and 7-position terminal strip for low impedance or constant voltage operation
Controls	Music / Voice switch, 70V/100V operation jumper
Mounting Points	Two (2) M8 rigging points
Included Accessories	Zinc-rich epoxy dual-layer powder-coated yoke, included integral safety cable mounting point
Environmental	IP55W per IEC 529, designed to MIL-STD-810G Color-matched ABS plastic input panel weather cover with 13.5mm ID gland nut installed in .82" knockout
Dimensions H x W x D	11.00" x 13.00" x 13.50" (279 x 330 x 343 mm)
Weight	34 lbs (15.4 kg) with included yoke
Finish	Refer to the Technical Drawing (page 3)

OPTIONS

Accessories	R-VTY35: Provides pan-tilt aiming functions. Zinc-rich dual-layer powder-coated steel with SS hardware, color-matched to loudspeaker. R-FRY35: Provides full rotation mounting capability for down-firing application (i.e. top of press box). Zinc-rich epoxy dual-layer powder-coated steel with SS hardware, color-matched to loudspeaker
--------------------	---

R.35-3896 THREE-WAY FULL-RANGE (90° x 60°) WEATHER-RESISTANT LOUDSPEAKER

AXIAL PROCESSED RESPONSE (dB)⁸

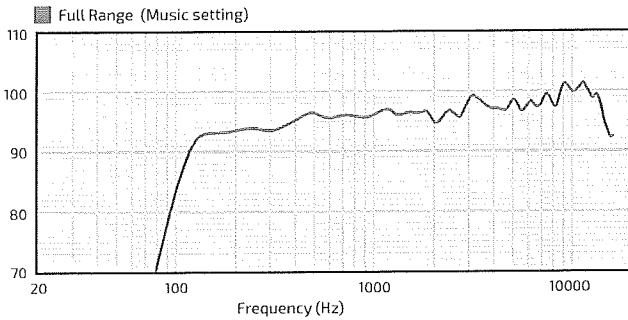

BEAMWIDTH (Degrees)¹²

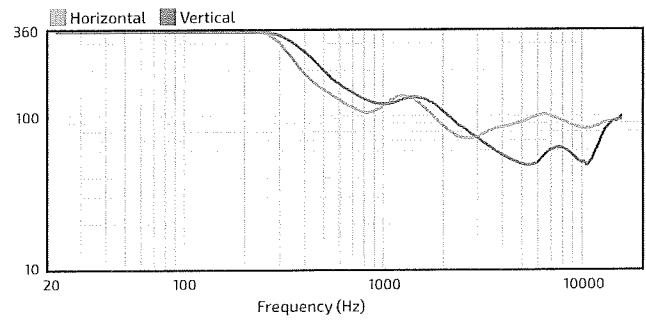

AXIAL SENSITIVITY (dB SPL)⁹

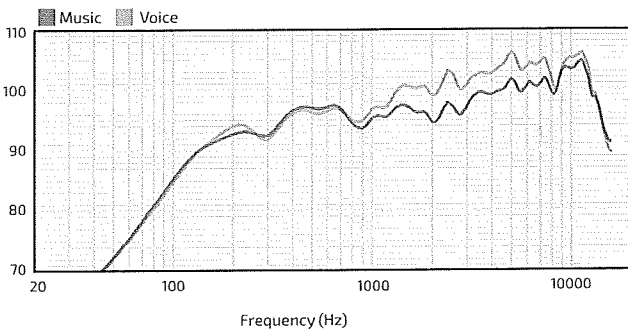

DIRECTIVITY INDEX (dB)¹¹

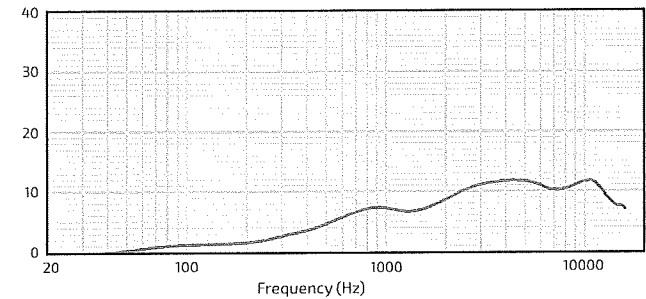

IMPEDANCE (Ohms)

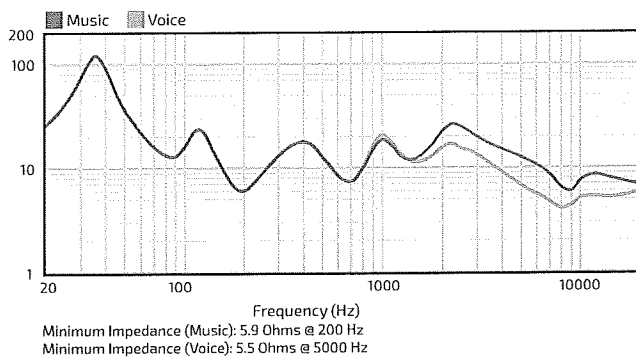

ARCHITECTURAL SPECIFICATIONS

The loudspeaker system shall be a three-way, full-range modified trapezoidal design with one 8-inch (203mm) high-output LF driver mounted triaxially behind a MultiSource Waveguide™ horn containing one 1-inch exit HF compression driver and two 2.35-inch midrange compression drivers. Drivers shall be connected to an integral crossover with crossover frequencies of 850 Hz and 2.7 kHz. The input connections shall be an NL4-type connector and a 7-position terminal strip for standard or autoformer tap operation. There is also a 2-position switch for voice or music applications. The system shall be equipped with a 200W high performance autoformer for use in 70.7V or 100V distributed audio systems, with 200W, 100W, 50W and 25W taps available in 70.7V distributed systems (200W, 100W and 50W taps available in 100V distributed systems). The loudspeaker enclosure shall be matte finish high impact ABS plastic with a 1mm perforated aluminum grille backed by hydrophobically-treated polyester mesh and open cell foam. There shall be two M8 rigging points, and an included dual-layer zinc-rich epoxy powder-coated steel mounting yoke. The LF, horn and cabinet shell are internally fused to create a monolithic, extremely rigid, resonance-free enclosure. The system shall have an operating range of 80 Hz to 16 kHz (-10 dB) and a low impedance (8 Ohm) input capability of 56V RMS. At the "Music" setting, it shall have a sensitivity on axis at 1W / 1m, 8 ohms nominal impedance, of 98 dB. At the "Voice" setting, it shall have a sensitivity at 1W / 1m, 8 ohms nominal impedance, of 100 dB. The nominal dispersion shall be 90° H x 60° V. The loudspeaker shall be 11" (279mm) H (front) x 13" (330mm) W x 13.5" (343mm) D and shall weigh 34 lbs (15.4 kg) with the included mounting yoke.

R.35-3896

THREE-WAY FULL-RANGE (90° x 60°)
WEATHER-RESISTANT LOUDSPEAKER

TECHNICAL DRAWING / DIMENSIONS / FINISH

H x W x D
11.00" x 13.00" x 13.50"
(279 x 330 x 343 mm)

Unit Weight
34 lbs (15.4 kg) loudspeaker and mount

Shipping Weight
40 lbs (18.1 kg)

Grille:
Powder-coated perforated marine-grade aluminum backed with hydrophobically-treated mesh and foam backing. Grey (RAL#7035), Black (RAL#9004) or White (RAL#9003)

Enclosure / Finish
Grey, Black or White matte paintable high-impact ABS

R.35-3896

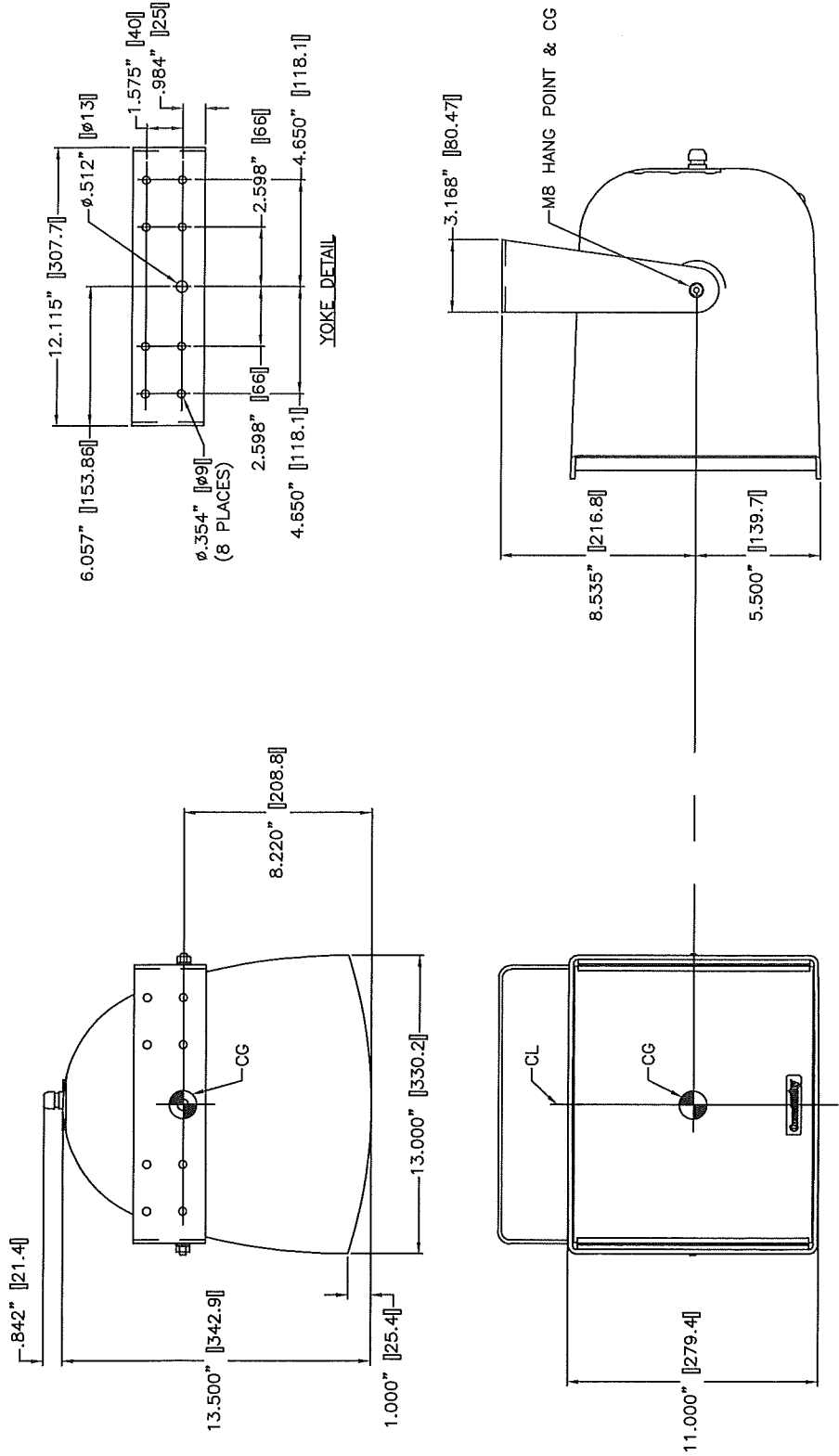

R SERIES Point Source

R.35-3896

THREE-WAY FULL-RANGE (90° x 60°)
WEATHER-RESISTANT LOUDSPEAKER

CONNECTION DIAGRAM

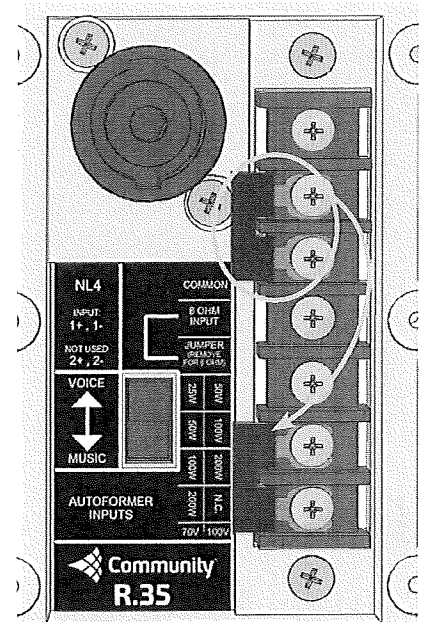
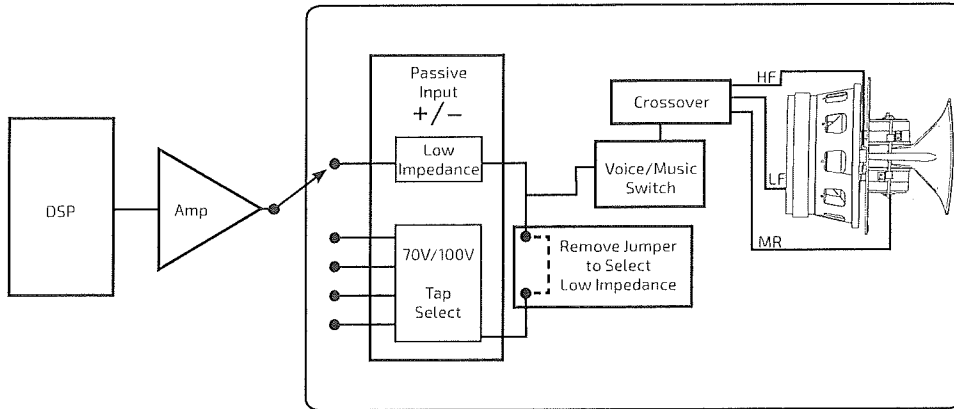

Must remove jumper, or move it to the bottom terminals, for 8Ω operation (see yellow arrow)

Input panel

NOTES

- PERFORMANCE SPECIFICATIONS** All measurements are taken indoor using a time-windowed and processed signal to eliminate room effects, approximating an anechoic environment, a distance of 6.0 m. All acoustic specifications are rounded to the nearest whole number. An external DSP with settings provided by Community Professional Loudspeakers is required to achieve the specified performance; further performance gains can be realized using Community's dSPEC226 loudspeaker processor with FIR power response optimization.
- OPERATING RANGE** The frequency range in which the on-axis processed response remains within 10dB of the average SPL.
- CONTINUOUS POWER HANDLING** Maximum continuous input voltage (and the equivalent power rating, in watts, at the stated nominal impedance) that the system can withstand, without damage, for a period of 2 hours using an EIA-426-B defined spectrum; with recommended signal processing and protection filters.
- NOMINAL SENSITIVITY** Averaged SPL over the operating range with an input voltage that would produce 1 Watt at the nominal impedance and the averaged SPL over the operating range with a fixed input voltage of 2.83V, respectively; swept sine wave axial measurements with no external processing applied in whole space, except where indicated.
- NOMINAL MAXIMUM SPL** Calculated based on nominal / peak power handling, respectively, and nominal sensitivity; exclusive of power compression.
- EQUALIZED SENSITIVITY** The respective SPL levels produced when an EIA-426-B signal is applied to the equalized loudspeaker system at a level which produces a total power of 1 Watt, in sum, to the loudspeaker subsections and also at a level which produces a total voltage, in sum, of 2.83V to the loudspeaker subsections, respectively; each referenced to a distance of 1 meter.
- EQUALIZED MAXIMUM SPL** The SPL produced when an EIA-426-B signal is applied to the equalized loudspeaker system, at a level which drives at least one subsection to its rated continuous input voltage limit, referenced to a distance of 1 meter. The peak SPL represents the 2:1 (6dB) crest factor of the EIA-426-B test signal.
- AXIAL PROCESSED RESPONSE** The on-axis variation in acoustic output level with frequency of the complete loudspeaker system with recommended signal processing applied. 1/6 octave Gaussian smoothing applied.
- AXIAL SENSITIVITY** The on-axis variation in acoustic output level with frequency for a 1 Watt swept sine wave, referenced to 1 meter with no signal processing. 1/6 octave Gaussian smoothing applied.
- HORIZONTAL / VERTICAL OFF-AXIS RESPONSES** The loudspeaker's magnitude response at various angles off-axis, with recommended signal processing applied in the operating mode which utilizes the largest number of individually amplified pass bands. 1/6 octave Gaussian smoothing applied.
- DIRECTIVITY INDEX** The ratio of the on-axis SPL squared to the mean squared SPL at the same distance for all points within the measurement sphere for each given frequency; expressed in dB. 1/6 octave Gaussian smoothing applied.
- BEAMWIDTH** The angle between the -6dB points in the polar response of the loudspeaker when driven in the operating mode which utilizes the largest number of individually amplified pass bands. 1/6 octave Gaussian smoothing applied.

Data presented on this spec sheet represents a selection of the basic performance specifications for the R.15COAX. These specifications are intended to allow the user to perform a fair, straightforward evaluation and comparison with other loudspeaker spec sheets. For a detailed analysis of this loudspeaker's performance, please download the GLL file and/or the CLF file from our website: communitypro.com

V2-212S DUAL 12-INCH SUBWOOFER SYSTEM



SPECIFICATIONS

Loudspeaker Type:	Dual driver subwoofer, rectangular, vented bass
Operating Range:	37 Hz to 500 Hz (-10 dB)
Frequency Response:	50 Hz to 125 Hz (-3 dB)
Max Input Ratings:	300W continuous, 750W program 34.6 volts RMS, 69.3 volts momentary peak
Sensitivity (1W/1m):	98 dB (50 Hz to 200 Hz) half space
Maximum Output:	123 dB SPL / 129 dB SPL (peak)
Nominal Impedance:	4 ohms
Minimum Impedance:	4.2 ohms @ 110 Hz
Nominal -6dB Beamwidth:	360° H x 180° V
Recommended Signal Processing:	40 Hz, 24 dB/octave high pass filter
Drivers:	LF 2 x 12-inch
Driver Protection:	DYNA-TECH protection circuitry
Input Connection:	NL4-compatible locking connector with terminal strip in parallel
Controls:	None
Enclosure:	18mm, 11-ply cross-laminated birch
Mounting/Rigging Provisions:	8 x M10 threaded rigging fittings
Finish:	Catalyzed polyester two-part paint, black or white
Grille:	Powder coated steel, black or white finish
Required Accessories:	None
Supplied Accessories:	Rubber feet, black (4)
Optional Accessories:	M10EYBLKIT 10mm eyebolt kit STKIT seat track kit
Dimensions—Height:	13.9 inches (354 mm) - not including feet
Width:	35.9 inches (912 mm)
Depth:	17.9 inches (455 mm)
Weight:	70 lbs (31.8 kg)
Model Options:	V2-212SB (black finish) V2-212SW (white finish)

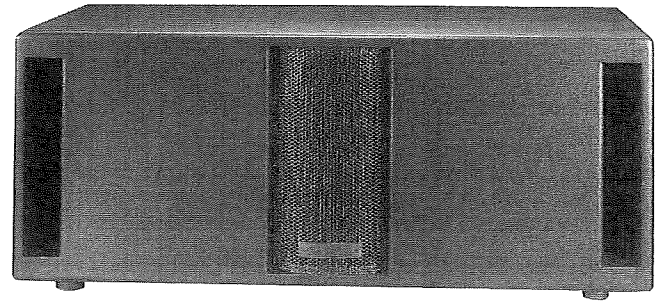

APPLICATIONS

- Fitness centers
- Nightclubs
- Bars and restaurants
- Houses of worship
- Theaters
- Themed attractions

FEATURES

- Low profile design fits tight spaces
- DYNA-TECH™ driver protection circuitry
- Patented Cool-Coil™ heat evacuation technology to minimize cone driver power compression
- Eight M10 threaded rigging fittings (four on each end panel)
- Terminal strip and NL4-compatible connectors
- Available in standard black or white finishes

DESCRIPTION

The V2-212S is a low-profile, dual-driver subwoofer system designed to augment and extend the low frequency output of any VERIS 2 full-range loudspeaker system. Powerful and low in distortion, the V2-212S produces authoritative low frequency output. The result is a deep, but punchy sonic signature that can handle most any musical style with ease. Solidly constructed of cross-laminated birch plywood, this subwoofer provides an accurate acoustic response uncolored by enclosure resonance. Its small size makes it a perfect fit for jazz clubs, bars, restaurants, worship centers, AV presentations, and other applications that require extended bass, but do not have the space available to install larger, bulkier systems.

The enclosure may be suspended from its M10 threaded rigging points, or simply located on the floor. As with all subwoofers, a corner placement is recommended when possible, in order to take advantage of the acoustical boundary effect for the highest possible efficiency. The V2-212S includes Community's exclusive DYNA-TECH™ driver protection circuitry to protect against abusive operating conditions, and also features Community's patented Cool-Coil™ heat evacuation technology to minimize cone driver power compression and ensure long-term reliability.

The V2-212S is a versatile performer for applications requiring high quality, high power, and extended low frequency response at a reasonable cost.

NOTES:

1. Sensitivity: Free field pink noise measurement at 6ft (1.8m) at 10% power; extrapolated to 1 meter and an input of 2.83 volts RMS.
2. Watts: All wattage figures are calculated using the rated nominal impedance.
3. Sensitivity: Subwoofers measurements are performed half-space.

V2-212S DUAL 12-INCH SUBWOOFER SYSTEM

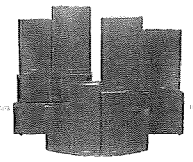

FREQUENCY RESPONSE

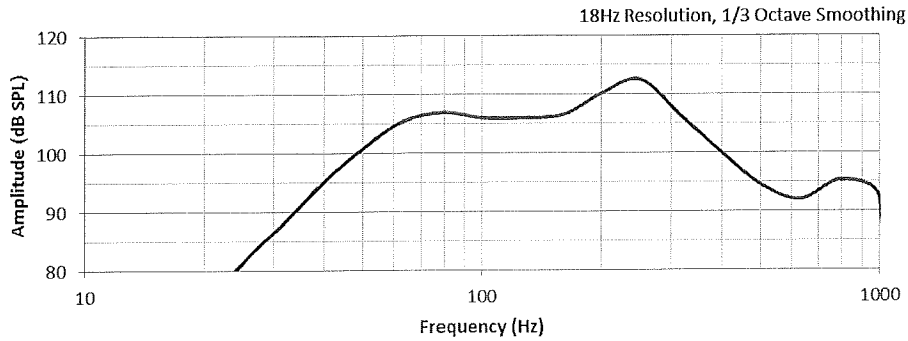

IMPEDANCE

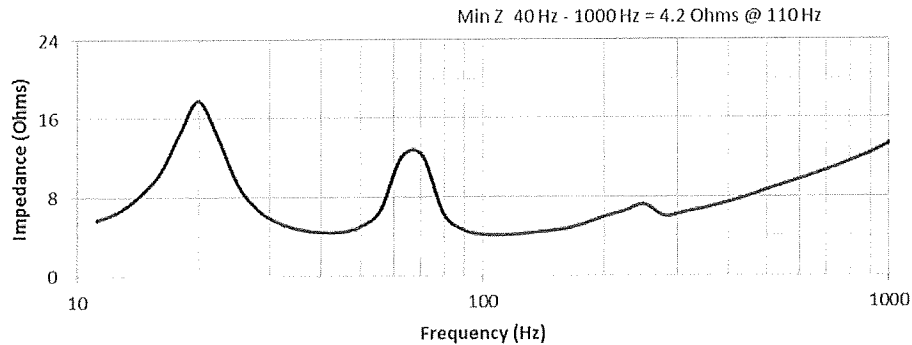

DIMENSIONS

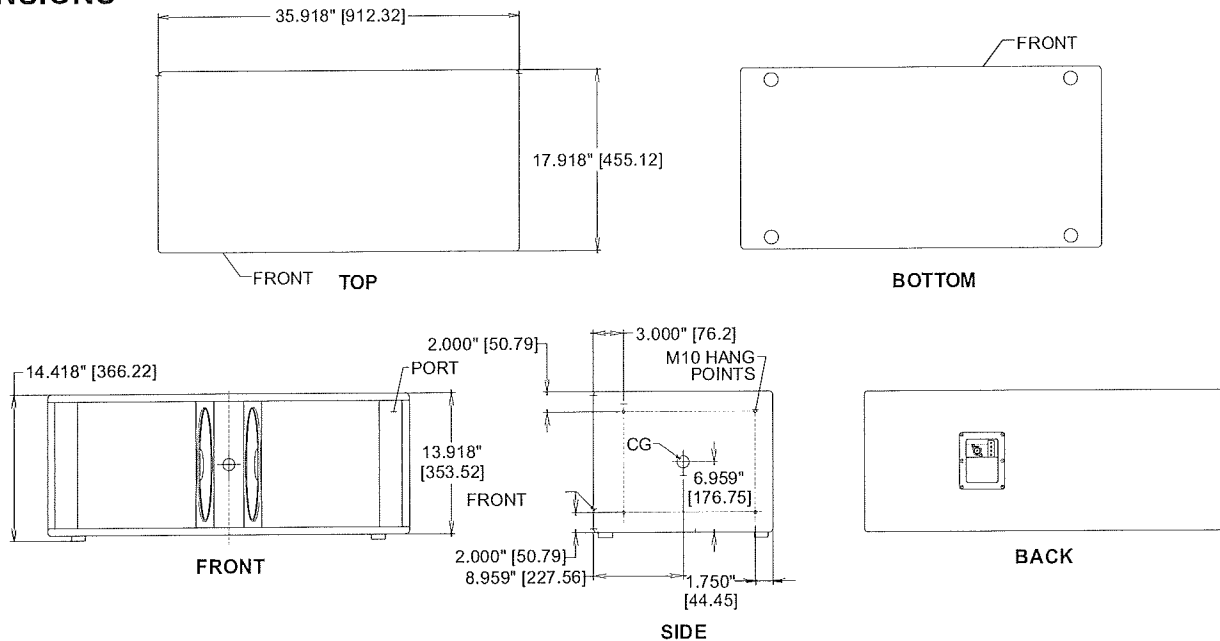

ARCHITECTURAL SPECIFICATIONS

The loudspeaker system shall be a low frequency, rectangular, vented bass, dual 12-inch driver subwoofer. There shall be an NL4-compatible locking connector with terminal strip in parallel. The loudspeaker enclosure shall be constructed of 18mm, 11-ply cross laminated birch with a perforated steel grille and shall be fitted with eight M10 flying/rigging inserts, four (4) on each end panel. The system shall have an amplitude response of 37 Hz to 500 Hz (-10 dB) and input capability of 34.6V RMS. The sensitivity at 1W/1m shall be 98 dB between 50 Hz to 200 Hz (half-space) at a nominal 4 ohm impedance. The nominal dispersion shall be 360° H x 180° V over its usable frequency range. The dimensions of the enclosure are defined as 13.9 in. (354 mm) H x 35.9 in. (912 mm) W x 17.9 in. (455 mm) D at a weight of 70 lbs (31.8 kg).

Community strives to improve its products on a continual basis. Specifications are therefore subject to change without notice.



CMXa Series

CMX 300Va | CMX 500Va |
CMX 800Va | CMX 2000Va

Professional Power Amplifiers

Features

- "Flex-Use" loading options allow you to drive low-impedance loads down to 2 ohms and certain models to drive 70 and 100V distributed loudspeaker systems
- "Flex-Use" Input connectivity choices including actively balanced barrier strip, XLR, or 1/4" TRS
- "Flex-Use" Output connectivity choices include NL4 Speakon™ and detachable terminal block
- Rack mountable with chassis less than 16" or 40.6 mm deep
- 1 dB recessed, detented gain controls for fast, accurate and repeatable settings
- Tamper-proof security cover for gain controls
- Recessed rear DIP switches for easy selection of stereo, parallel, or bridged mode operation, and the additional choice of enabling/disabling low frequency filter protection
- Low-noise variable-speed fans with rear-to-front airflow keep amplifiers and racks cool

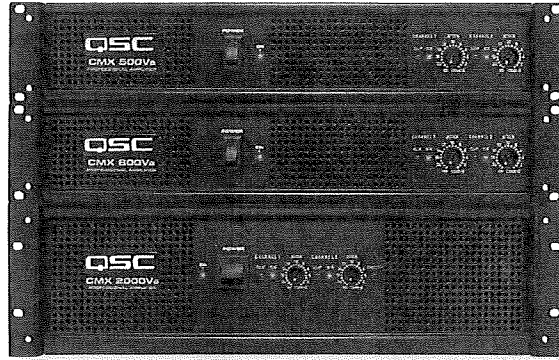

The New CMXa Series is an economical and rugged power amplifier designed to meet the needs of system integrators. It is based upon the proven, rock-solid, reliable performance found in the award winning RMX Series. The CMXa feature sets are designed for wide-ranging application in facilities such as performance halls, houses of worship, sports clubs, gymnasiums, dance venues, pubs, and FGM/BGM systems. The CMXa Series provides unmatched performance, the right power for the job and an affordable price point.

Proven and Reliable Power Plant

CMXa amplifiers incorporate everything QSC has learned in more than forty years of striving to deliver worry-free operations without failures. The design of these amplifiers starts with our world-class power supplies. The CMXa uses a powerful, high-current toroidal transformer and filtering to ensure generous energy reserves. This allows the amplifiers to effortlessly handle high-level transients, even when driving abusive 2 ohm speaker loads.

The amplifier output sections feature rugged class AB and class H architecture depending on power level. Efficient class H output sections on the CMX 800Va and CMX 2000Va reduce AC current draw and cut down on waste heat.

All CMXa amplifiers are protected from damage from shorted outputs. Automatic current limiting protects the amplifier from damage until the short is corrected.

CMXa amplifiers also feature DC protection systems to prevent loudspeaker damage in

the unlikely event of an output transistor failure. DC voltage from the power supply is never passed directly to your speakers, even in the event of an output circuit failure.

Superior Performance

The CMXa amplifiers deliver true and accurate studio-quality sound. A full complementary output circuit using high-grade linear output devices generates accurate, flat-frequency response with low distortion. SMT (Surface Mount Technology) triples small-signal component density, enabling high power output in a 2 rack unit chassis (3 RU for the CMX 2000Va). Unlike other designs, CMXa output devices are directly mounted to the heat sink for optimum thermal coupling and cooling.

The CMXa Series is available in four models. Three 2-rackspace models range in power from 300 to 800 watts per channel at 4 ohms. One 3-rackspace model provides 2500 watts per channel at 2 ohms. All four models feature a compact chassis less than 16" deep.

The V in the model name designates the ability to directly drive 70-volt and/or 100-volt distributed loudspeakers. The CMX 300Va and CMX 500Va must be configured for bridged-mono operation in order to directly drive high-impedance systems while the CMX 800Va and 2000Va may be used in either stereo or mono mode.

For installations requiring a transformer isolated output, the CMX has optional accessories to cover your needs.

CMXa Power Amplifiers

		Watts per channel			
2RU Models	8Ω	4Ω*	2Ω**	Bridged 4Ω**	
CMX 300Va	200	300	430	830	
CMX 500Va	300	500	700	1400	
CMX 800Va	500	800	1200	2400	
		Watts per channel			
3RU Model	8Ω	4Ω**	2Ω**	Bridged 4Ω**	
CMX 2000Va	1100	2000	2500	5000	

1 kHz, 0.1% THD *1 kHz, 0.5% THD **1 kHz, 1% THD

CMXa Details

	CM X300Va	CMX 500Va	CMX 800Va	CMX 2000Va
Stereo Mode (both channels driven)				
8Ω / FTC 20 Hz – 20 kHz / 0.1% THD	185 W	260 W	450 W	1050 W
8Ω / EIA 1 kHz / 0.1% THD	200 W	300 W	500 W	1100 W
4Ω / FTC 20 Hz – 20 kHz / 0.1% THD	280 W	400 W	650 W	1600 W
4Ω / EIA 1 kHz / 0.5% THD	300 W	500 W	800 W	2000 W (1% THD)
2Ω / EIA 1 kHz / 1% THD	430 W	700 W	1200 W	2500 W
70V Direct Drive / EIA 1 kHz / 1% THD	–	–	400 W	2500 W
100V Direct Drive / EIA 1 kHz / 1% THD	–	–	–	1000 W
Bridge Mono Mode				
8Ω / FTC 20 Hz – 20 kHz / 0.1% THD	530 W	800 W	1300 W	3200 W
8Ω / EIA 1 kHz / 0.1% THD	600 W	900 W	1500 W	3600 W
4Ω / EIA 1 kHz / 1% THD	830 W	1400 W	2400 W	5000 W
70V Direct Drive / EIA 1 kHz / 1% THD	600 W	1200 W	2000 W	5000 W
100V Direct Drive / EIA 1 kHz / 1% THD	–	600 W	2300 W	3600 W
Signal to Noise (20 Hz – 20 kHz, 8Ω)	> -100 dB	> -100 dB	> -100 dB	> -100 dB
Input Sensitivity at 8Ω	1.15 V (+3.4 dBu)	1.14 V (+3.4 dBu)	1.23 V (+4.0 dBu)	1.42 V (+5.3 dBu)
Voltage Gain at 8Ω	31.6 x (30 dB)	40 x (32 dB)	46 x (33 dB)	64 x (36 dB)
Output Circuitry	Class AB	Class AB	2-tier Class H	3-tier Class H
Power Requirements				
Typical, 1/8 power pink noise at 4Ω, 120 VAC	4.4 A	5.4 A	6.3 A	13.9 A
Typical, 1/8 power pink noise at 4Ω, 230 VAC	2.2 A	2.7 A	3.2 A	7 A
Severe, 1/3 power pink noise at 4Ω, 120 VAC	6.6 A	9.6 A	15.6 A	26.9 A
Severe, 1/3 power pink noise at 4Ω, 230 VAC	3.3 A	4.8 A	7.8 A	13.5 A
Distortion (SMPTE-M)	< 0.02%	< 0.01%	< 0.01%	< 0.01%
Distortion (typical)				
20 Hz – 20 kHz: 10 dB below rated power	< 0.03% THD / 4Ω and 8Ω			
1.0 kHz and below: full-rated power	< 0.03% THD / 4Ω and 8Ω			
Frequency Response	20 Hz – 20 kHz: ±1 dB	-3 dB points: 5 Hz – 50 kHz		
Damping Factor (1 kHz and below)	> 300 at 8Ω			
Input Impedance	10k ohms unbalanced, 20k ohms balanced			
Input Clipping	10 Vrms (+22 dB)			
Cooling	Continuously variable-speed fan, rear-to-front air flow			
Connectors (each channel)	Input: Active balanced; barrier strip, XLR and 1/4" (6.3 mm) – TRS tip and XLR pin 2 positive Output: Detachable terminal block and Neutrik™ Speakon™			
Controls	Front: AC switch, Ch. 1 & 2 gain knobs Rear: 10-position DIP switch			
Indicators	Power-on: Green LED / Signal: Green LED (1 per channel) / Clip: Red LED (1 per channel)			
Amplifier Protection	Stable into reactive or mismatched loads			
Load Protection	On/off muting, AC coupling (CMX 300Va and CMX 500Va), triac crowbar (CMX 800Va and CMX 2000Va on each channel)			
Power Requirements	120 and 230 VAC, 50 – 60 Hz			
Dimensions (HWD)				
2 RU models	3.5" (8.9 cm) 2 rack spaces x 19" (48.3 cm) rack mounting x 15.9" (40 cm) deep to rear support ears			
3 RU model (CMX 2000Va)	5.25" (13.3 cm) 3 rack spaces x 19" (48.3 cm) rack mounting x 15.9" (40 cm) deep to rear support ears			
Weight - Net	35 lb (15.9 kg)	40 lb (18.2 kg)	44.5 lb (20.2 kg)	75 lb (33.1 kg)
Weight - Shipping	41 lb (18.6 kg)	46 lb (20.9 kg)	50.5 lb (23 kg)	87 lb (37.2 kg)

Specifications subject to change without notice.



1675 MacArthur Boulevard • Costa Mesa, CA 92626 • Ph: 800/854-4079 or 714/957-7100 • Fax: 714/754-6174

© 2013 QSC Audio Products, LLC. All rights reserved. QSC and the QSC logo are registered trademarks of QSC Audio Products, LLC in the U.S. Patent and Trademark office and other countries. Speakon is a trademark of Neutrik. All other trademarks are the property of their respective owners. Patents may apply or be pending.

CMXa Spec Sheet 08/9/2013



please recycle

DATA SHEET

TESIRAFORTÉ® AI

FIXED I/O DSP

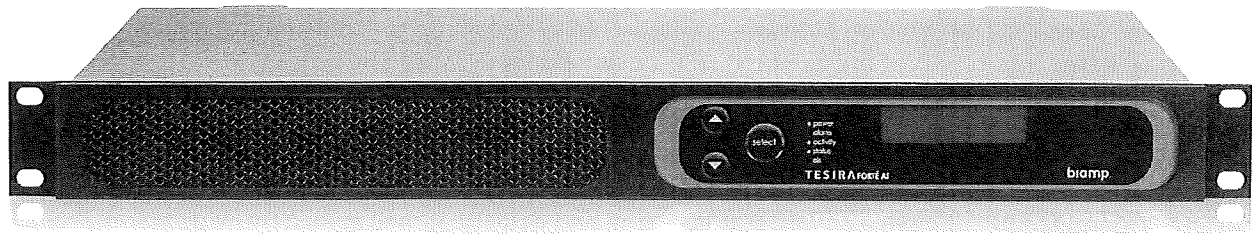

TesiraFORTÉ® AI is a fixed I/O DSP with 12 analog inputs and 8 analog outputs and includes up to 8 channels of configurable USB audio. USB audio allows TesiraFORTÉ to interface directly with USB audio hosts, as well as to take full advantage of today's most sophisticated conferencing solutions. TesiraFORTÉ AI also provides extensive audio processing, including but not limited to: signal routing and mixing, equalization, filtering, dynamics, and delay, as well as control, monitoring, and diagnostic tools; all configured through the Tesira configuration software. TesiraFORTÉ AI is best-suited for small- to medium-sized rooms that require high-quality audio solutions using voice lift and mix-minus, such as conference rooms or council chambers.

BENEFITS

- Includes default configuration file, allowing for plug-and-play usage
- Highly scalable and cost-effective solution that can grow over time with the needs of the customer
- SpeechSense™ technology enhances speech processing
- Integrates directly with soft codecs and other USB audio hosts

FEATURES

- 12 mic/line level inputs, 8 mic/line level outputs
- Gigabit Ethernet port
- Up to 8 channels of configurable USB audio
- RS-232 serial port
- 4-pin GPIO
- 2-line OLED display with capacitive-touch navigation
- Rack mountable (1RU)
- Supports port authentication via IEEE 802.1X
- System configuration and control via Ethernet
- Internal universal power supply
- Signal processing via intuitive software allows configuration and control for signal routing, mixing, equalization, filtering, delay and much more
- CE marked, UL listed, and RoHS compliant
- Covered by Biamp Systems' 5-year warranty

Biamp, Tesira, and TesiraFORTÉ are either trademarks or registered trademarks of Biamp Systems, LLC in the United States and other countries. Other product names referenced may be trademarks or registered marks of their respective owners and Biamp Systems is not affiliated with or sponsored by these companies.

ARCHITECTS & ENGINEERS SPECIFICATION

The fixed I/O DSP shall be designed exclusively for use with Tesira® systems. The fixed I/O DSP shall support Ethernet connection for programming and control on a RJ-45 connector. The fixed I/O DSP shall have internal DSP processing. The fixed I/O DSP shall include 4 channels of General Purpose Input and Output connection (GPIO) for sending or receiving logic signals. The programming of the GPIO ports shall be software configurable. The fixed I/O DSP shall include a RS-232 connection for control data transmission into or out of the fixed I/O DSP and such operation shall be software programmable. The fixed I/O DSP shall include a Universal Serial Bus (USB) connection on a standard USB-B type connector. The fixed I/O DSP shall be software configurable to stream up to 8 channels of digital USB Class 1 Audio transmission either into or out of the fixed I/O DSP or simultaneous input and output. The fixed I/O DSP shall support port authentication via IEEE 802.1X. The fixed I/O DSP shall provide 12 balanced input connections for receiving of microphone or line level analog audio signals on screw-down, removable connectors. The fixed I/O DSP shall provide 8 balanced output channels for the transmission of microphone or line level analog audio signals on screw-down, removable connectors. Each individual channel shall have its own dedicated connection. The fixed I/O DSP shall provide front panel OLED identification of device power, status, alarm, and activity as well as system-wide alarm. The fixed I/O DSP shall be rack mountable (1RU) and feature software-configurable signal processing, including but not limited to: signal routing and mixing, equalization, filtering, dynamics, and delay, as well as control, monitoring, and diagnostic tools. The fixed I/O DSP shall be CE marked, UL listed, and shall be compliant with the RoHS directive. Warranty shall be five years. The fixed I/O DSP shall be TesiraFORTÉ® AI.

TESIRAFORTÉ AI SPECIFICATIONS

Frequency Response: 20Hz to 20kHz, +4dBu output: +0.25 dB/-0.5 dB		Crosstalk, channel to channel, 1 kHz: 0dB gain, +4dBu input: < -85dB 54dB gain, -50dBu input: < -75dB	
THD+N (22Hz to 22kHz): 0dB gain, +4dBu input: < 0.006% 54dB gain, -50dBu input: < 0.040%		Sampling Rate: 48kHz	
EIN (no weighting, 22Hz to 22kHz): < -125dBu		A/D - D/A Converters: 24-bit	
Dynamic Range (in presence of signal) 22Hz to 22kHz, 0dB gain: > 108dB		Power Consumption: 100-240VAC 50/60Hz: < 35W	
Input Impedance (balanced): 8kΩ		USB: Bit Depth: 16- or 24-bit Number of Channels: up to 8 Sample Rate: 48kHz	
Output Impedance (balanced): 207Ω		Environment: Ambient Operating Temperature Range: 32-104° F (0-40° C) Humidity: 0-98%, non-condensing Altitude: 0-6,600 feet (0-2000 Meters) MSL	
Maximum Input: +24dBu		Compliance: FCC Part 15B (USA) CE marked (Europe) UL und C-UL listed (USA and Canada) RCM (Australia) RoHS Directive (Europe)	
Maximum Output (selectable): +24dBu, +18dBu, +12dBu, +6dBu, 0dBu, -31dBu			
Input Gain Range (6dB steps): 0-66dB			
Overall Dimensions: Height: 1.75 inches (44 mm) Width: 19.0 inches (483 mm) Depth: 10.5 inches (267 mm) Weight: 8 lbs (3.63 kg)			
Phantom Power: +48VDC (7mA/input)			

TESIRAFORTÉ AI BACK PANEL

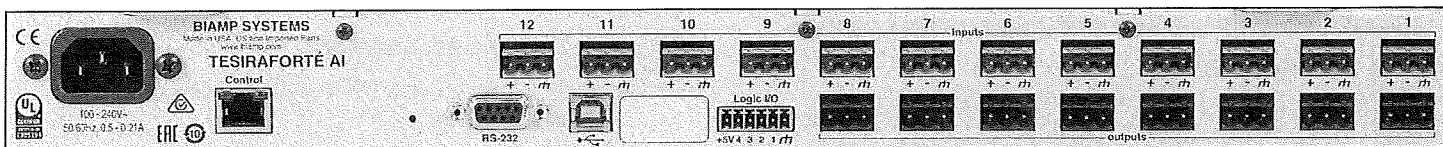

DATA SHEET

TESIRA® TEC-1s AND TEC-1i

ETHERNET CONTROL

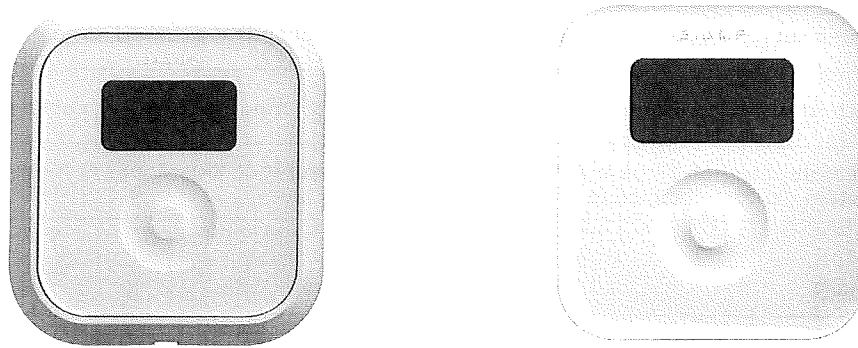

TEC-1s and TEC-1i are remote controls for Tesira[®] and TesiraFORTÉ systems. They offer a simple, intuitive interface for end users and can be installed and configured to fit the unique needs of a particular application. The device connects via standard CAT-5/6/7 cabling and is powered over Ethernet, eliminating the need for custom cabling and local power sources. Multiple remote control panels can be connected over large distances using standard network technology. TEC-1s is designed to mount to a surface and includes a molded rear chassis with accommodation for cabling and for physically attaching the entire assembly to a surface. TEC-1i is designed to mount into a wall or surface without a rear chassis to ensure the smallest physical profile.

FEATURES

- Adjustment and/or initiation of 32 selectable system volumes and actions
- Volumes are any individual or grouped system levels, including inputs, outputs, matrix cross-points, etc.
- Actions are any individual or grouped system operations, including presets, source selection, mutes, ducking, combining, etc.
- Control functions are programmed in the Tesira system design software
- High contrast OLED display with a wide viewing angle
- The display brightness can be adjusted to fit the ambient light present in the application and automatically dims when not in use
- Capacitive touch technology eliminates protruding and moving parts to increase product reliability and longevity while simplifying cleaning
- TEC-1s surface mounts to any wall; multiple mounting options accommodate international back boxes
- TEC-1i flush mounts to any wall; mounts using the retrofit plate (included) or installs in a Raco[®] 254 box for North American installations (not included)
- 330' (100m) Ethernet cable length can be extended with standard PoE network technology (routers, switches, hubs, media converters)
- Connects with standard RJ-45 or IDC connector
- Covered by Biamp Systems' 5-year warranty

ARCHITECTS & ENGINEERS SPECIFICATION

The control panel shall provide programmable remote control of volume and selection functions for Biamp's Tesira and TesiraFORTÉ products. The control shall be a PoE network appliance with a graphical display and a capacitive touch scroll wheel for menu navigation and selection. The connection shall be made using a standard RJ-45 or IDC connector. The control shall be available as a surface mounted device that shall not require any type of electrical box be present for mounting and available in another form factor as an in-surface device without a backbox. The control shall be made from white PVC/ABS material with UV protection additive. Warranty shall be five years. The control panel shall be a Biamp TEC-1s for surface mount applications and TEC-1i for in-surface applications.

APPLICATIONS

Source Selection	Selection and level control of input sources for background music, such as CD player and auxiliary devices
Paging/Music	Zone page routing and music source selection with independent page/music volume control
Restaurant/Bar	Music source selection and room volume control, independent per zone, or in a single centralized control
A/V Conferencing	Individual source volume control and selection of room mode presets (i.e., conferencing or video playback)
Room Combining	Remote selection of room combinations, based on preset configurations or moveable partitions, with automatic combining of volume functions

TEC-1s SPECIFICATIONS

Dimensions	5.1"H x 4.7"W x 1.25"D (130mm x 120mm x 32mm)
Weight	0.5 lb (0.2kg)
Power Consumption	PoE+ (IEEE 802.3at Class 1, 4W)
Control Cable Requirements	Unshielded twisted pair (UTP) wiring, 100BaseT interface (CAT-5/6/7 Ethernet cable) using either RJ-45 or Insulation Displacement Connector (IDC)
Control Cable Length	330' (100m) Ethernet cable length can be extended with standard PoE network technology
Control Wiring Topology	Standard Ethernet network wiring
Control Programming	Each control configured for specific operation by the system design software
Compliance	RoHS Directive; CE; FCC

TEC-1i SPECIFICATIONS

Dimensions	6.22"H x 5.82"W x 0.5"D (158mm x 148mm x 12.7mm)
Weight	0.5 lb (0.2kg)
Power Consumption	PoE+ (IEEE 802.3at Class 1, 4W)
Control Cable Requirements	Unshielded twisted pair (UTP) wiring, 100BaseT interface (CAT-5/6/7 Ethernet cable) using either RJ-45 or Insulation Displacement Connector (IDC)
Control Cable Length	330' (100m) Ethernet cable length can be extended with standard PoE network technology
Control Wiring Topology	Standard Ethernet network wiring
Control Programming	Each control configured for specific operation by the system design software
Compliance	RoHS Directive; CE; FCC

SURGEX[®] SX115R, RT and RL Series Mode Pro™ Surge Suppressors and Power Conditioners With Impedance Tolerant™ EMI/RFI Filtering

U.S. Patents 4,870,534 and 4,870,528



SX115 RL Front



SX115 RT Front

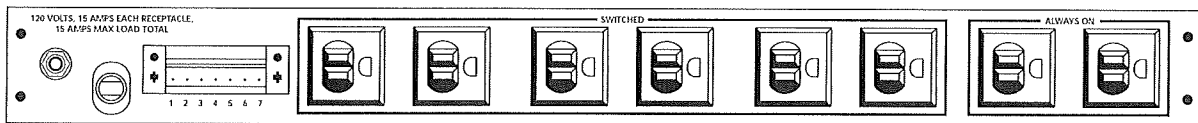

SX115 RT Back

The SurgeX SX115 Series provides guaranteed surge protection and power conditioning for audio, video and computer equipment. SX115 Series surge suppressors are 15-amp load-capable and feature advanced *Impedance Tolerant* EMI/RFI filtering circuitry. All models have eight standard grounded AC receptacles. Six receptacles are switched; two are always on. In addition, both R and RT models provide a front panel courtesy outlet.

Designed for recording studios, custom design/build installations and sound reinforcement applications, the SX115 RL includes front-panel connectors for Littlite gooseneck lamps.

The SX115 RT includes remote turn-on capability, making it ideal for designed power distribution systems with a sequential controller such as the SurgeX SX2120 SEQ.

SurgeX patented *Series Mode Pro* surge suppression technology is superior to conventional MOV circuitry. It provides proven, reliable protection, stopping multiple surges of up to 6,000 volts and unlimited surge current, without producing ground contamination.

These components meet the most stringent government purchase specifications for powerline surge suppressors. Their A-1-1 rating assures you of dependable protection from destructive spikes, surges and inductive transients.

SURGE PROBLEMS ARE HISTORY!



SURGEX[®]

Professional AC Power Products

6131-B Kellers Church Road
Pipersville, PA 18947
PH 215-766-1240
FAX 215-766-9202
www.surgex.com

SURGEX SX1115R, RT and RL *Series Mode Pro*TM Surge Suppressors and Power Conditioners With *Impedance Tolerant*TM EMI/RFI Filtering

U.S. Patents 4,870,534 and 4,870,528

SPECIFICATIONS

Load Rating: 15 amps @ 120 volts.

UL 1449-2 Adjunct Classification Test Results: 1000 surges, 6000 volts, 3000 amps, C1 pulse, measured suppressed voltage 290 volts, no failures.

1996 Federal Guidelines, Grade A, Class 1, Mode 1: SX1115R, RT and RL meet guidelines.

Limiters (3 circuits): Series surge reactor current limiter. Cascaded, auto-tracking dual polarity voltage limiter. Dual pulse inverters.

Clamping Voltage Onset: 172 volts nominal (2 volts above peak line voltage, auto-tracking).

Filter (bi-directional, wave tracking): With 50 ohm load: 3 dB @ 3 kHz; 38 dB @ 100 kHz; 50 dB @ 300 kHz; 50 dB @ 5 MHz; 50 dB @ 30 MHz

Let-Through Slew Rate: 5000 volt/μs disturbance reduced to 28 volt/μs within power wave envelope; less than 10 volt/μs outside power wave envelope.

Snubber: Instant-reacting snubber for fast-rising surges generated within the building.

Maximum Applied Surge Pulse Joule Rating: Unlimited, due to surge current limiting (8 x 20 μs).

Maximum Applied Surge Pulse Voltage: 6000 volts (1.2 x 50 μs pulse), industry standard rating.

Maximum Applied Surge Pulse Current: 100,000 amperes (8 x 20 μs).

Endurance, IEEE C62.41-1991 Category B3 (C1) Pulses: 1 kv>500,000; 3 kv>10,000; 6 kv>1000 (NRTL-UL certified).

ARCHITECTURAL AND ENGINEERING SPECIFICATIONS

The surge suppressor shall be a one-rack-space unit in a magnetic shielding steel enclosure. It shall operate from 120 volts AC and have a 9-foot, grounded, 3-wire #14 line cord. There shall be 8 standard three-prong AC receptacles (9 on R and RT models) and a self-test circuit with visual indicator. Six outlets shall be switched, two shall be always on. Overall dimensions shall be 1.75" H x 19" W x 8" D. Weight shall be 9 pounds.

The surge suppressor shall have a load rating of 15 amps @ 120 volts and provide advanced Impedance Tolerant EMI/RFI filtering and power conditioning. It shall meet 1996 Federal Grade A, Class 1, Mode 1 Guidelines for powerline surge suppressors. There shall be three limiter circuits: a series surge reactor current limiter, a cascaded auto-tracking dual-polarity voltage limiter, and dual pulse inverters. The onset clamping voltage shall be 172 volts, nominal, and the unit shall have an instant-reacting snubber to protect against fast-rising surges generated within the installation location. The surge suppressor shall have unlimited Applied Surge Current rating and shall withstand at least 1000 occurrences of Surge Pulse Voltages up to 6000 volts.

FEATURES

- Made in U.S.A.
- Magnetic shielding steel enclosure
- 9' grounded 3-wire #14 line cord
- 8 grounded AC outlets on rear panel (6 switched, 2 always on)
- Front panel courtesy outlet (R and RT models)
- Advanced Impedance Tolerant EMI/RFI filtering
- Remote turn on (RT model)
- Connectors for Littlite gooseneck lamps (RL model)
- Thermal circuit breaker overload protection
- Self-test circuit with visual indicator
- Dimensions: 1.75" H x 19" W x 8" D (4.45 x 48.26 x 20.32 cm)
- Weight: 9 lbs (4.1 kg)

WHEN DOWNTIME IS NOT AN OPTION!

SURGEX[®]

Professional AC Power Products

6131-B Kellers Church Road
Pipersville, PA 18947
PH 215-766-1240
FAX 215-766-9202
www.surgex.com

Power up to 4 Wireless Access Points or Other PoE-capable Devices

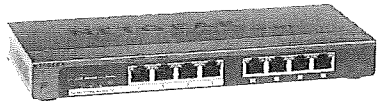

- Senses and adjusts for network speed and cabling type
- Durable case and silent, fan-less design
- Auto power-down mode saves energy when port is unused
- Auto Green mode detects cable length and adjusts power usage

Features

- Fast, auto-switching Ethernet connection integrates 10, 100, and 1,000 Mbps devices into your network
- Supports Windows® and Macintosh® platforms
- LEDs make it easy to monitor link, speed, and activity
- AutoUplink™ technology automatically adjusts for two common types of cables



NETGEAR Green

- Auto power-down mode saves energy when port is unused
- Auto Green mode detects cable length and adjusts power usage to save energy

Features	FS105	FS108	FS116	FS108P	FS116P	GS105	GS108	GS108P	GS116	JFS516	JFS524	JGS516	JGS524
10/100 Mbps Ports	5	8	16	8	16					16	24		
10/100/1000 Mbps Ports						5	8	8	16			16	24
Auto Uplink™	●	●	●	●	●	●	●	●	●	●	●	●	●
Internal Power Supply										●	●	●	●
Metal Enclosure	●	●	●	●	●	●	●	●	●	●	●	●	●
Port LEDs	●	●	●	●	●	●	●	●	●				
Rack Mountable										●	●	●	●
Power over Ethernet (PoE)				4	8			4					
Warranty†	Lifetime	Lifetime	Lifetime	Lifetime	Lifetime	Lifetime	Lifetime	Lifetime	Lifetime	Lifetime	Lifetime	Lifetime	Lifetime



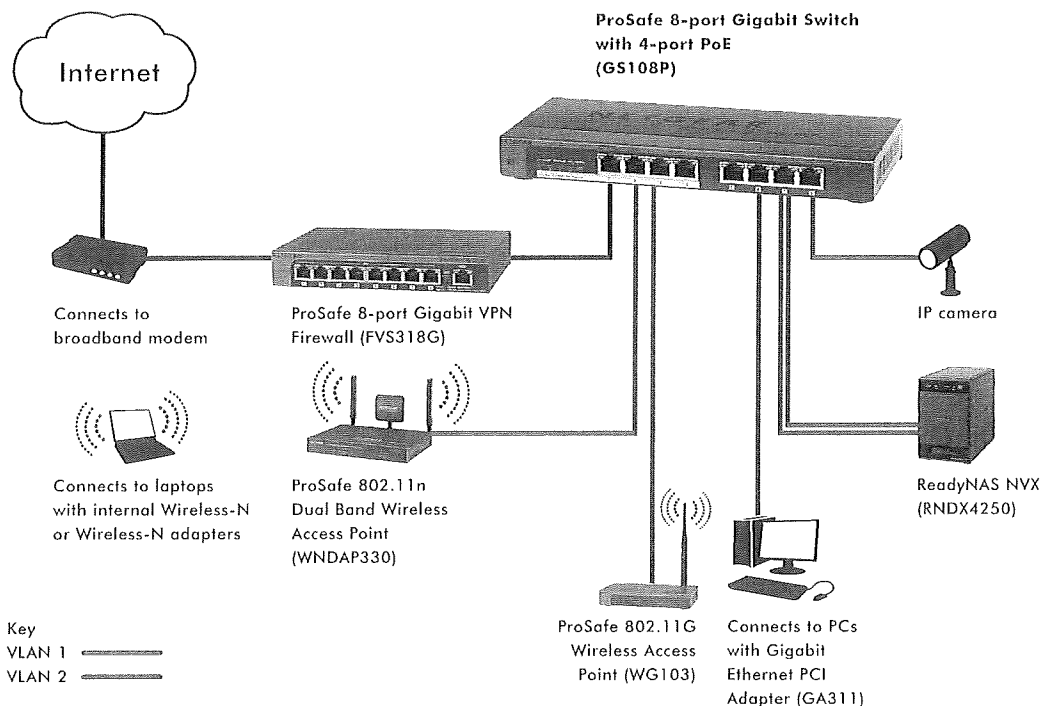

Technical Specifications

• Network Protocol and Standards Compatibility

- IEEE 802.3i 10BASE-T
- IEEE 802.3u 100BASE-TX
- IEEE 802.3ab 1000BASE-T Gigabit Ethernet
- IEEE 802.3x flow control
- IEEE 802.3af DTE power via MDI

• Power Supply

- Total power consumption: 60W maximum
- 802.3af power consumption: 50W maximum (ports 1-4)
- 48V DC, 1.25A power output; plug is localized to country of sale

• Network Ports

- 8 auto speed-sensing 10/100/1000 RJ-45 ports

• Physical Specifications

- Dimensions (H x W x D):
27 x 235 x 103 mm (1.1 x 9.3 x 4.1 in)
- Weight: 0.716 kg (1.7 lb)

• Performance Specifications

- Forwarding mode: Store-and-forward
- Queue buffer memory: 192 KB per port
- Bandwidth: 16 Gbps (non-blocking)
- Forwarding rate:
 - 10 Mbps port: 14,880 packets/sec
 - 100 Mbps port: 148,800 packets/sec
 - 1000 Mbps port: 1,488,000 packets/sec
- Latency (using 1500-byte packets):
 - 10 Mbps: 30μs (max)
 - 100 Mbps: 6μs (max)
 - 1000 Mbps: 4μs (max)
- MAC address database: 4K

• Electromagnetic Emissions

- CE mark, commercial
- FCC Part 15 Class B
- VCCI Class B
- C-Tick
- EN 55022 (CISPR 22) Class B

• Environmental Specifications

- Operating temperature: 32° to 122° F (0° to 50° C)
- Storage temperature: -4° to 158° F (-20° to 70° C)
- Operating humidity: 90% maximum relative humidity, non-condensing
- Storage humidity: 95% maximum relative humidity, non-condensing
- Operating altitude: 10,000 ft (3,000 m) maximum
- Storage altitude: 10,000 ft (3,000 m) maximum

• Status LEDs

- System: Power, PoE maximum power
- Per port: Link, activity, speed, PoE active, PoE fault

• Safety

- CE mark, commercial
- CE/LVD EN 60950

System Requirements

- Category 5 UTP network cables or above
- Network card for each PC
- Network software (e.g., Windows®)
- Web browser (e.g., Internet Explorer 5.0 or higher, Netscape 6.0 or higher)

Warranty

- NETGEAR Lifetime Warranty†
- Power supply: NETGEAR 2-year Warranty

ProSupport Service Packs Available

- **OnCall 24x7, Category 1**
 - PMB0331-100 (US)
 - PMB0331 (non-US)
- **XPressHW, Category 1**
 - PRR0331

Package Contents

- ProSafe® 8-port 10/100/1000 Gigabit Switch with 4-port PoE (GS108P)
- AC adapter
- Wall-mount kit
- Installation guide
- Warranty/support information card

Ordering Information

- North America: GS108P-100NAS
- Europe: GS108P-100EUS
- Asia: GS108P-100PES

NETGEAR®

350 E. Plumeria Drive
San Jose, CA 95134-1911
1-888-NETGEAR (638-4327)
E-mail: info@NETGEAR.com
www.NETGEAR.com

© 2009 NETGEAR, Inc. NETGEAR, the NETGEAR Logo, NETGEAR Digital Entertainer Logo, Connect with Innovation, FrontView, IntelliFi, PowerShift, ProSafe, ProSecure, RAIDar, RAIDiator, RangeMax, ReadyNAS, Smart Wizard, X-RAID, and X-RAID2, are trademarks and/or registered trademarks of NETGEAR, Inc. and/or subsidiaries in the United States and/or other countries. Mac and the Mac logo are trademarks of Apple Inc., registered in the U.S. and other countries. Other brand names mentioned herein are for identification purposes only and may be trademarks of their respective holder(s). Information is subject to change without notice. All rights reserved.

This product comes with a limited warranty, the acceptance of which is a condition of sale. This product has been tested for quality assurance and this product or its components may have been recycled.

*Basic technical support provided for 90 days from date of purchase.

†Lifetime warranty for product purchased after 05/01/2007.

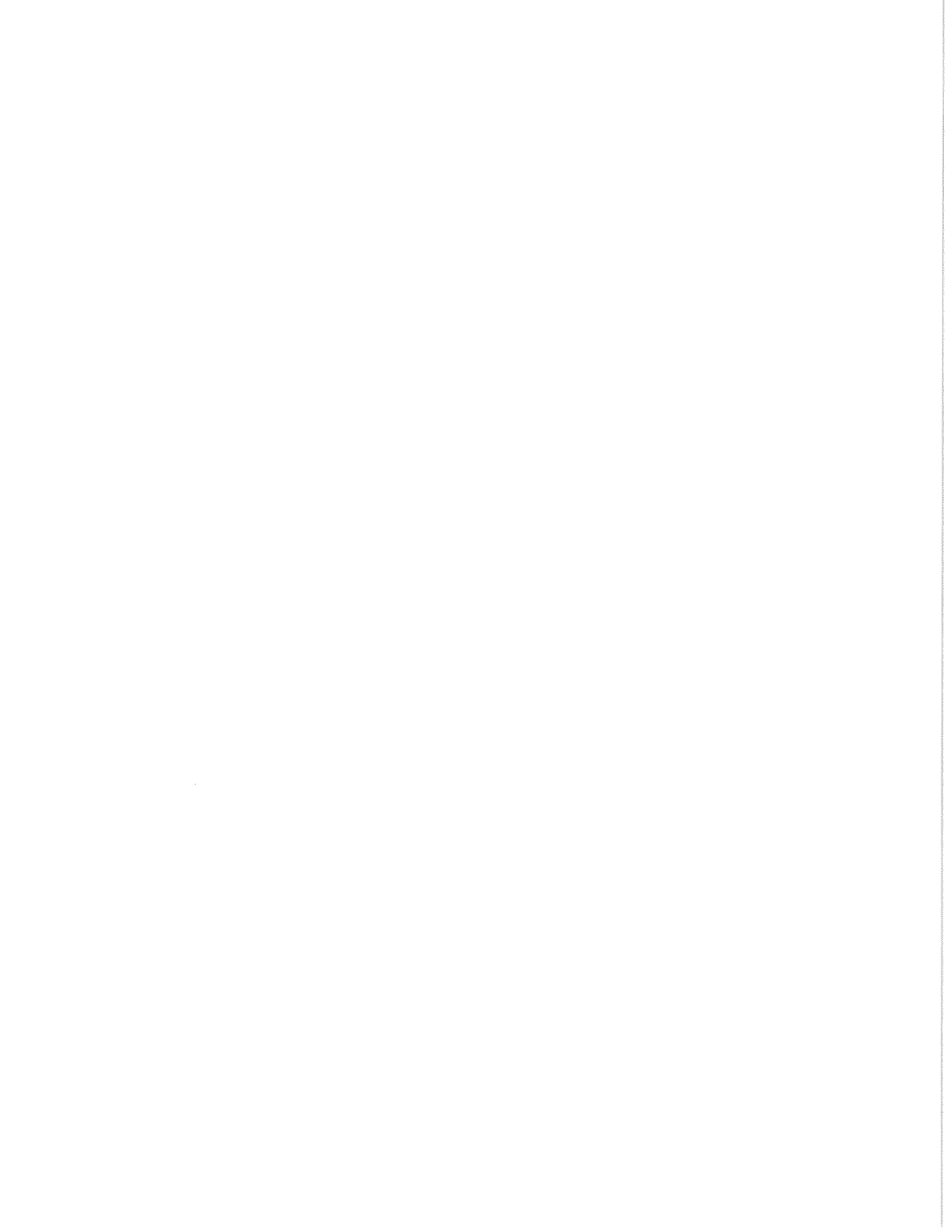

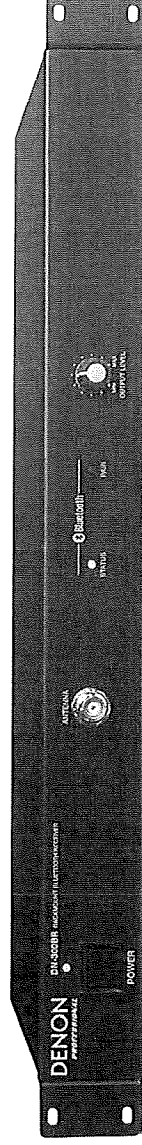

DN-300BR Rackmount Bluetooth Receiver

Key Features:

- 1 RU rackmount receiver
- Adds stereo Bluetooth 4.0 reception to any audio system
- Pairs up to (8) devices
- Balanced XLR and unbalanced RCA output
- Remote pairing button connection on rear (Euroblock mating connector included)

Specifications:

- Frequency Response: 20 Hz - 18 kHz (± 1 dB)
- Signal-to-Noise Ratio: > 83 dB (1 kHz, Unity)
- THD: $< 0.33\%$ (1 kHz, Unity)
- Channel Separation: < -68 dB (1 kHz, Unity)
- Output Level
 - Balanced: $+4$ dBu
 - Unbalanced: -10 dBv
- Bluetooth Specifications

- BNC antenna input for Denon remote Bluetooth antenna (included)

Overview:

The DN-300BR is a 1RU Bluetooth® 4.0 audio receiver with professional-grade audio outputs enabling the user to add wireless stereo Bluetooth® audio connectivity to any professional audio system. The DN-300BR can store up to (8) devices in its internal memory. The paired Bluetooth® device can send audio via balanced XLR and unbalanced RCA jacks to a mixer, powered loudspeakers or amplification system.

The included Bluetooth® antenna can be mounted to the front or rear panel for convenience, and facilitates up to 100 ft (33m) of reception. Ideal for retail, sports bars, education and hotel/conference applications.

An added feature is a Euroblock connection on the rear of the unit for a remote pairing button. This is convenient when the DN-300BR is not easily accessible. Front-mounted Output Level knob and Pairing/Status LEDs for ease-of-use.

- Version: 4.0
- Profiles: GAVDP 1.2, AVDTP 1.0, A2DP 1.2, Hands-Free Profile 1.5, Headset Profile 1.1
- Supported Codecs: SBC, MP3, AAC, aptX
- Range: Up to 100 feet / 30.5 meters*
- Output Class: Class 2
- Connectors
 - (2) XLR outputs
 - (1) RCA stereo output pair
 - (1) IEC power cable input
- Power
 - Connection: IEC
 - Voltage: 100-240 VAC, 50/60 Hz
 - Consumption: < 2 W
- Environmental Conditions
 - Operating Temperature: 41 - 113 °F (5 - 45 °C)
 - Operating Humidity: 25 - 85%, no condensation
- Dimensions (width x depth x height)
 - With rack ears: 19.0" x 10.7" x 1.7" (483 x 271 x 44mm)
 - Without rack ears: 17.1" x 10.7" x 1.7" (434 x 271 x 44mm)
- Weight: 6.6 lbs (3.0 kg)
- *Bluetooth / wireless reception and range are affected by walls, obstructions and movement. For optimal performance, make sure the antenna is connected and place the product in the center of the room so it is unobstructed by walls, furniture, etc

Product Specifications

SM35 Performance Headset Condenser Microphone

Overview

The new SM35 headset condenser microphone from Shure gives multi-instrumentalists the freedom to express themselves without having to sacrifice the sound quality found in traditional microphones. A tight, unidirectional (cardioid) pickup pattern provides excellent rejection of off-axis sound sources to prevent feedback and signal bleed for superior performance on stage. Standard TA4F (TQG) connectivity seamlessly integrates into any Shure wireless bodypack system, and its availability in a number of bundled systems makes it appropriate for any stage, ranging from small clubs to large installations and arena tours. The SM35-XLR (optional) includes an inline RPM626 preamp for use in standard wired (XLR) applications.

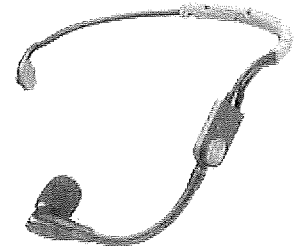

SM35

Features

- Wearable wireframe headset fits securely and comfortably for active performers and multi-instrumentalists
- Tight, unidirectional (cardioid) condenser pickup pattern rejects signal bleed and feedback for use on loud stages and behind floor monitors
- Flexible gooseneck design allows for optimized placement to further improve source isolation
- Lightweight and low-profile form enables comfortable, long-wearing use
- TA4F connector compatible with any Shure wireless bodypack system
- Included in a wide variety of Shure wireless systems, renowned for their ease of use and reliable performance
- Locking snap-fit windscreens tames plosive, breath and wind noise for clean and intelligible sound
- Tailored frequency response refined for clear, crisp vocal reproduction
- Legendary Shure precision engineering for durability and performance

Available Models

SM35-TQG	Headset Cardioid Condenser Microphone with Snap-fit Windscreen and TA4F (TQG) Connector
SM35-XLR	Headset Cardioid Condenser Microphone with Snap-fit Windscreen and Inline XLR Preamp
BLX1288/SM35	BLX Dual-Channel Wireless Combo System
BLX14/SM35	BLX Wireless Headset System
BLX188/SM35	BLX Dual-Channel Wireless Headset System
BLX14R/SM35	BLX Rack-Mounted Wireless Headset System
GLXD14/SM35	GLX-D Digital Wireless Headset System
SLX14/SM35	SLX Wireless Headset System
ULXD14/SM35	ULX-D Digital Wireless Headset System
ULXP14/SM35	ULX Professional Wireless Headset System
ULXS14/SM35	ULX Standard Wireless Headset System

Specifications

Type	Electret Condenser
Frequency Response	40 Hz to 20,000 Hz
Polar Pattern	Unidirectional (Cardioid)
Output Impedance @ 1 kHz	2400 Ω
Audio Output Level	-59.0 dBV/Pa
Signal-To-Noise Ratio ¹¹ @ 1 kHz	55 dB
Maximum SPL ¹¹ 1000 Ω load, @ 1% THD	153.0 dB
Dynamic Range ¹¹ @ 1 kHz, 1000 Ω load	114.0 dB
Equivalent Output Noise ¹¹ Typical, A-Weighted	39 dB
Power Requirements	+5 V DC (nominal), 10 V maximum (DC bias)
Polarity	Positive pressure on diaphragm produces positive voltage on pin 3 with respect to pin 1
Cable	1.1 m (45 in.)
Connector	TA4F
Net Weight	72 g (2.53 oz.)

¹¹ Measurements taken using RPM626 preamp

* All specifications measured with a 48 VDC phantom power supply. The microphone operates at lower voltages, but with slightly decreased headroom and sensitivity.

Optional Accessories

RK378	Replacement kit with clip + 2 snap-fit foam windscreens
RK183WS	Replacement snap-fit foam windscreens (4 per pkg.)

Polar Patterns

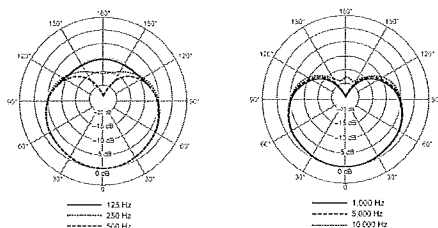

Frequency Response

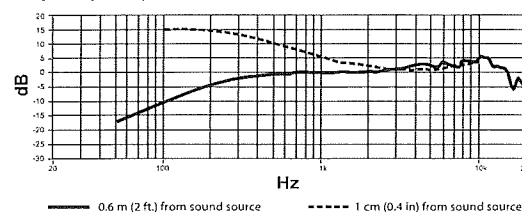

SHURE

LEGENDARY
PERFORMANCE™

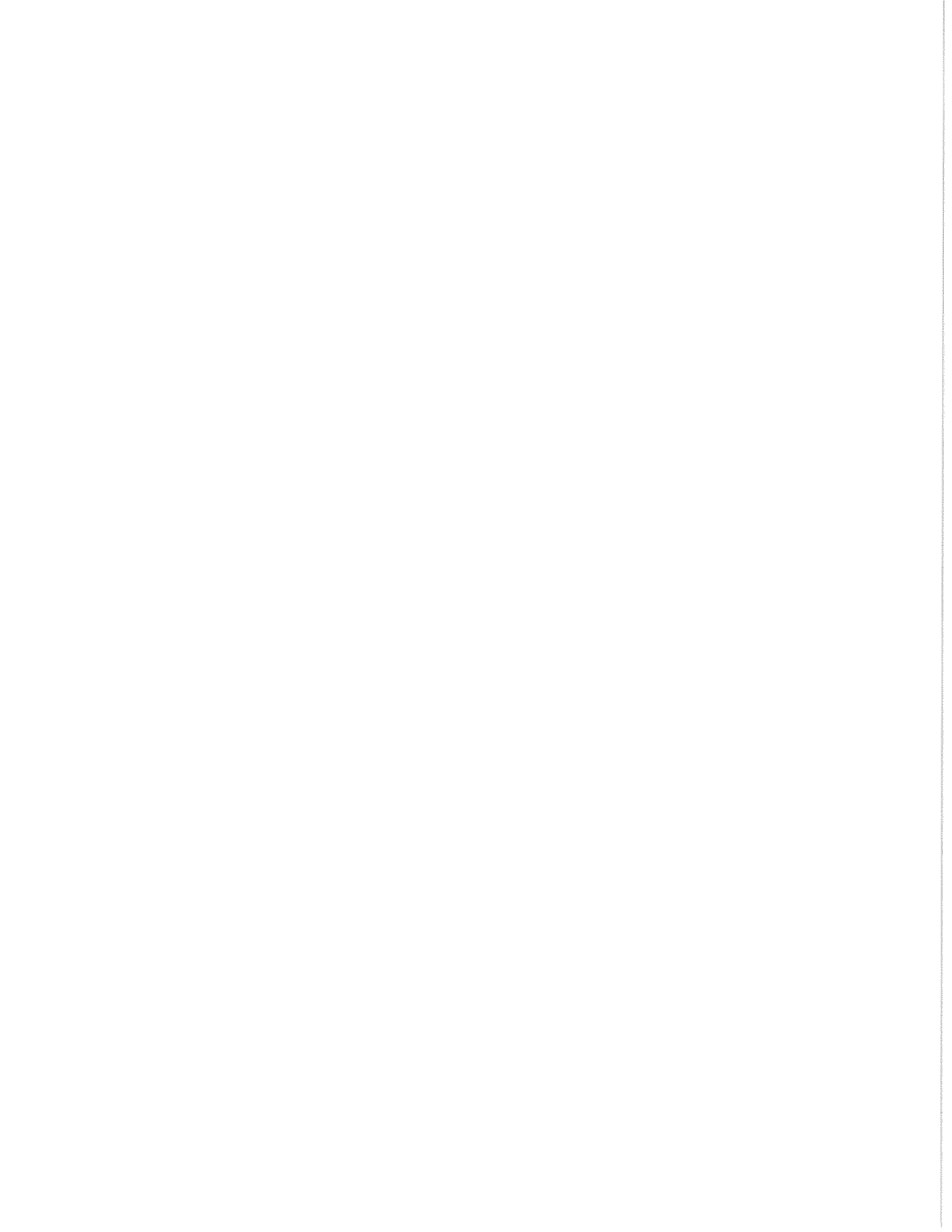

MODEL MX400 SERIES MICROPHONES

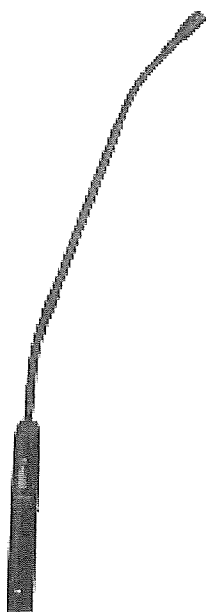

OVERVIEW

Shure Microflex® MX400 Series microphones are miniature gooseneck-mounted electret condenser microphones designed primarily for speech and vocal pickup. They can be mounted on lecterns, pulpits, or conference tables. All models include a preamplifier and are available with interchangeable cardioid, supercardioid, or omnidirectional cartridges.

FEATURES

- Wide dynamic range and frequency response for accurate sound reproduction across the audio spectrum
- Interchangeable cartridges provide the right polar pattern for every application
- Balanced, transformerless output for increased immunity to noise over long cable runs
- Shock mount that provides over 20 dB isolation from surface vibration noise
- Locking flange mount for permanently securing microphone to lecterns, pulpits, or conference tables
- Snap-fit foam windscreen

MODEL VARIATIONS

- **MX412:** 305 mm (12 in.) gooseneck microphone.
- **MX418:** 457 mm (18 in.) gooseneck microphone.
- **MX412S:** 305 mm (12 in) gooseneck microphone; includes a mute switch and an LED.
- **MX418S:** 457 mm (18 in) gooseneck microphone; includes a mute switch and an LED.

SPECIFICATIONS

Frequency Response (Figure 1)

50 to 17,000 Hz

Polar Pattern (Figure 2)

Output Impedance (at 1000 Hz)

Rated at 150 Ω (180 Ω actual)

Open Circuit Sensitivity (at 1 kHz, ref. 1 V/Pascal*)

Cardioid: -35.0 dB (17.8 mV)

Supercardioid: -33.5 dB (21.1 mV)

Omnidirectional: -27.5 dB (42.2 mV)

All settings -12 dB at 0 gain

*1 Pascal = 94 dB SPL

Maximum SPL (1 kHz at 1% THD, 1 k Ω load)

Cardioid: 124.2 dB

Supercardioid: 122.7 dB

Omnidirectional: 116.7 dB

All settings +6 dB at 0 gain

Equivalent Output Noise (A-weighted)

Cardioid: 28.0 dB SPL

Supercardioid: 26.5 dB SPL

Omnidirectional: 20.5 dB SPL

Signal to Noise Ratio (referenced at 94 dB SPL)

Cardioid: 66.0 dB

Supercardioid: 67.5 dB

Omnidirectional: 73.5 dB

Dynamic Range at 1 k Ω Load

96.2 dB

100 dB at 0 gain

Common Mode Rejection

45.0 dB minimum

Mute Switch Attenuation (switched models only)

50.0 dB minimum

Preamplifier Output Clipping Level (1% THD)

-6.0 dBV (0.5 V)

-12 dB at 0 gain

Polarity

Positive sound pressure on diaphragm produces positive voltage on pin 2 relative to pin 3 of output connector.

Power Requirements

11 to 52 Vdc phantom, 2.0 mA

Environmental Requirements

Operating Temperature Range: -18° C to 57° C (0° F to 135° F)

Relative Humidity: 0 to 95%

Dimensions (Figure 3)

Certification

Eligible to bear CE Marking. Conforms to European EMC Directive 89/336/EEC. Meets applicable tests and performance criteria in European Standard EN55103 (1996) parts 1 and 2, for residential (E1) and light industrial (E2) environments.

Portable Desktop Base

A412B

Stand Adapter

A57E

Omnidirectional Cartridge

R183B

Supercardioid Cartridge

R184B

Cardioid Cartridge

R185B

Snap-fit Foam Windscreen (4)

RK412WS

Shock Mount

A400SM

REPLACEMENT PARTS

Foam Ball Windscreen

A99WS

Locking Metal Windscreen

A412MWS

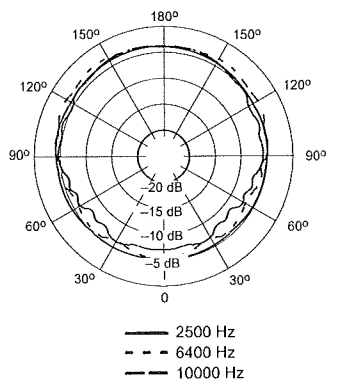
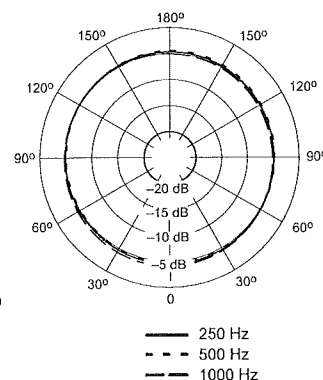
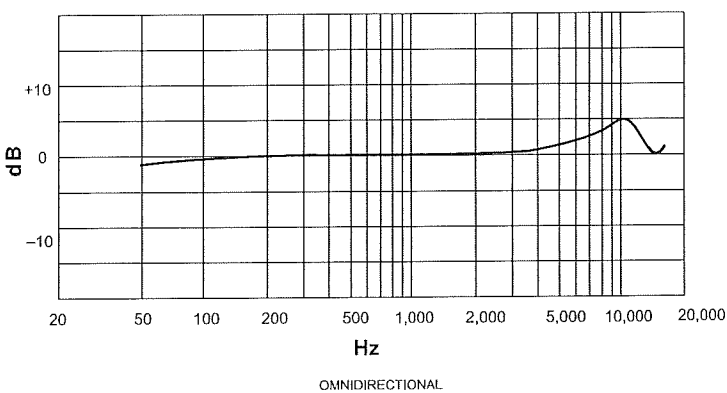
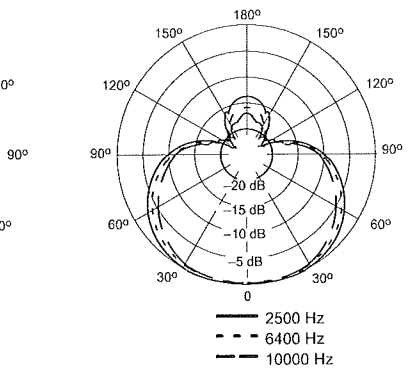
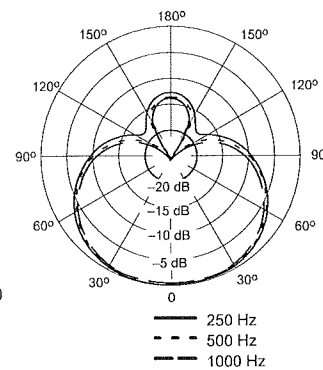
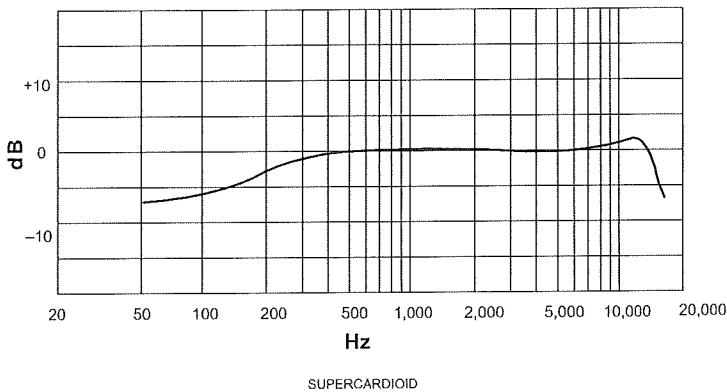
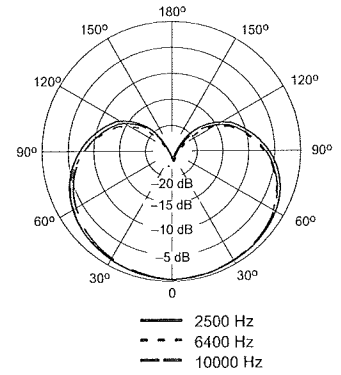
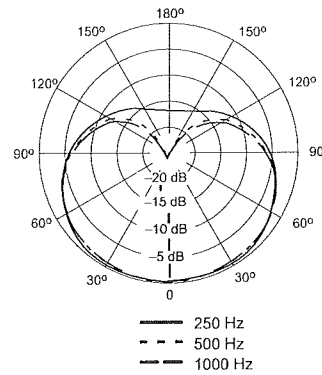
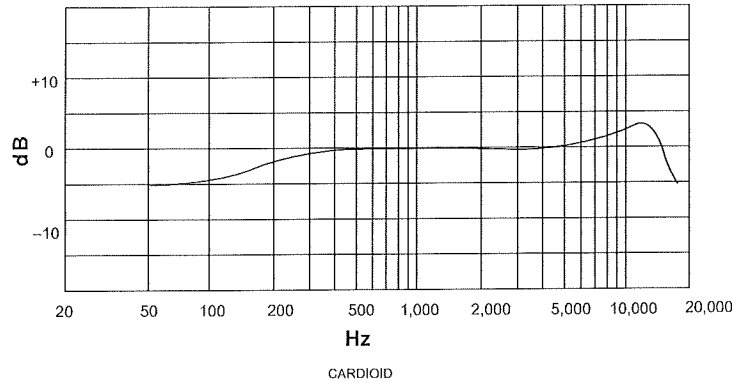

TYPICAL FREQUENCY RESPONSE
Figure 1

TYPICAL POLAR PATTERNS
Figure 2

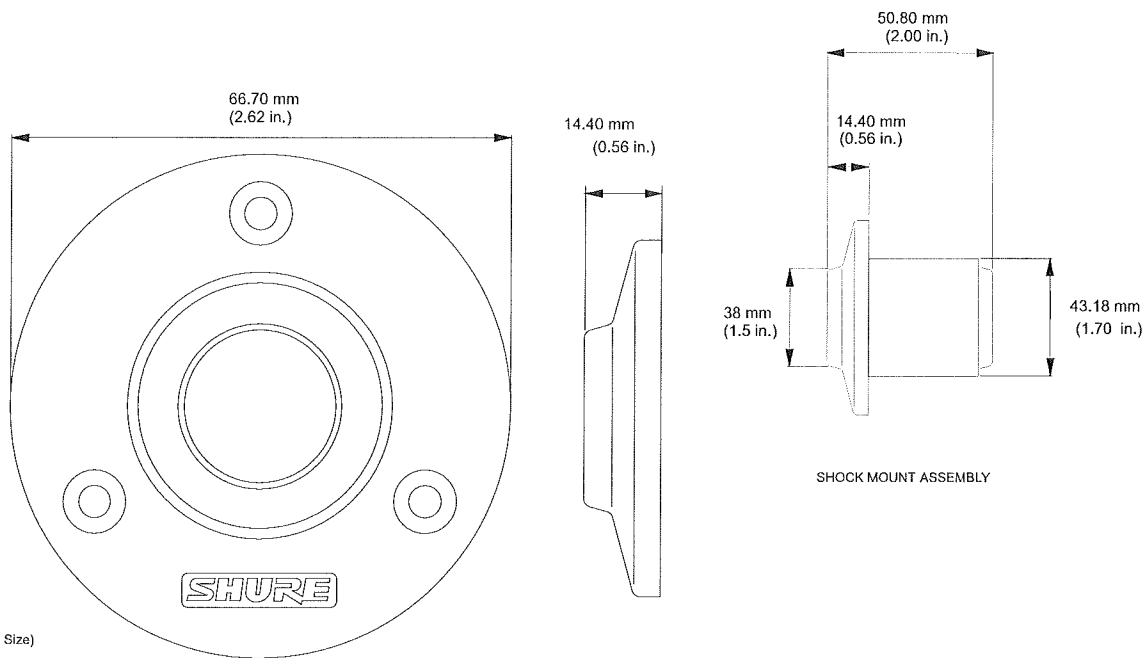
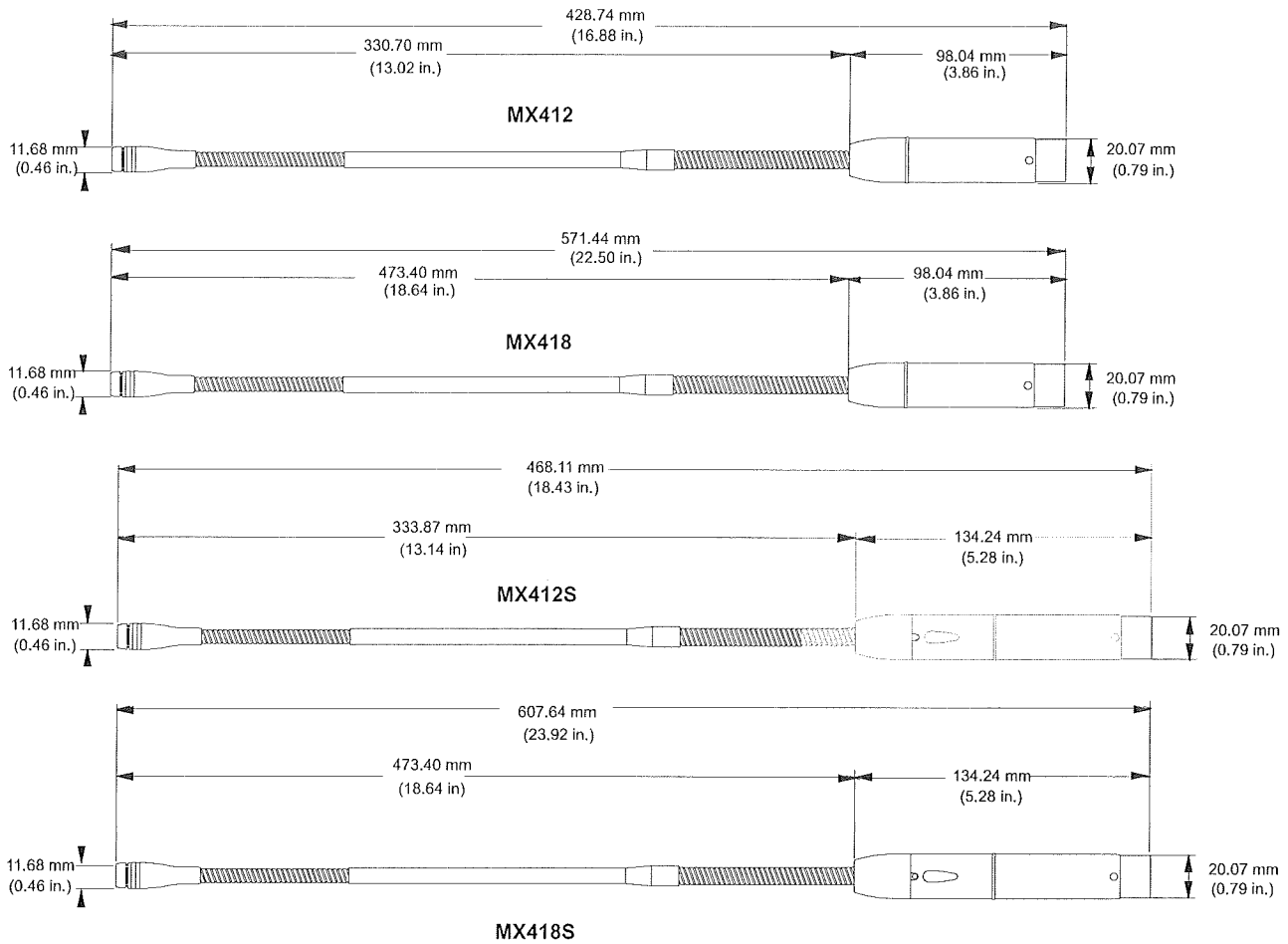

DIMENSIONS
Figure 3

MODEL SM58[®]
UNIDIRECTIONAL DYNAMIC MICROPHONE

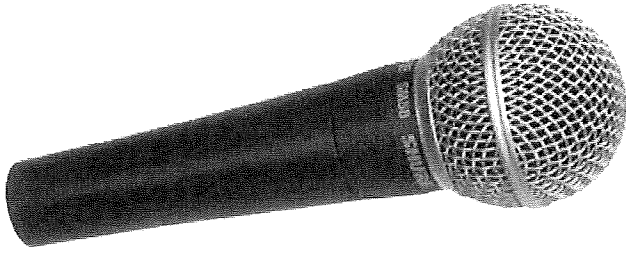

OVERVIEW

The Shure SM58[®] is a unidirectional (cardioid) dynamic vocal microphone designed for professional vocal use in sound reinforcement and studio recording. A highly effective, built-in, spherical filter minimizes wind and breath "pop" noise. A cardioid pickup pattern isolates the main sound source while minimizing unwanted background noise. The SM58 has a tailored vocal re-

sponse for a sound which is a world standard. Rugged construction, a proven shock mount system, and a steel mesh grille ensure that even with rough handling, the SM58 will perform consistently. Outdoors or indoors, singing or speech—the SM58 is the overwhelming choice of professionals worldwide.

FEATURES

- Frequency response tailored for vocals, with brightened midrange and bass rolloff
- Uniform cardioid pickup pattern isolates the main sound source and minimizes background noise
- Pneumatic shock-mount system cuts down handling noise
- Effective, built-in spherical wind and pop filter

- Supplied with break-resistant stand adapter which rotates 180°
- Legendary Shure quality, ruggedness, and reliability

SPECIFICATIONS

Type
Dynamic (moving coil)

Frequency Response
50 to 15,000 Hz

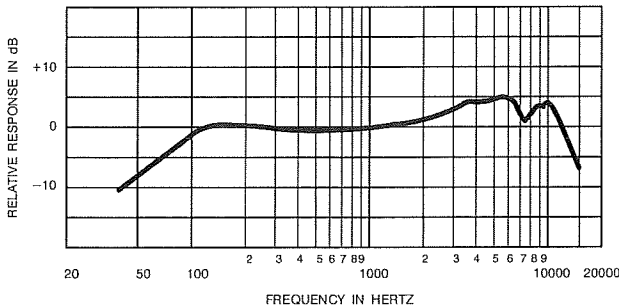

TYPICAL FREQUENCY RESPONSE

Models

- SM58
- SM58S (With On/Off Switch)

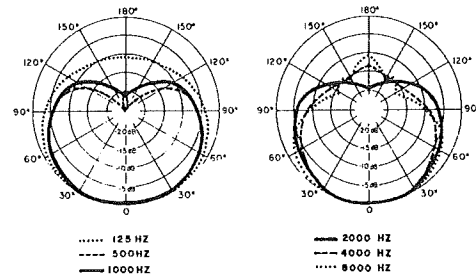

TYPICAL POLAR PATTERNS

Sensitivity (at 1,000 Hz Open Circuit Voltage)
-54.5 dBV/Pa (1.85 mV)
1 Pa = 94 dB SPL

Impedance

Rated impedance is 150 Ω (300 Ω actual) for connection to microphone inputs rated low impedance

Polarity

Positive pressure on diaphragm produces positive voltage on pin 2 with respect to pin 3

Polar Pattern

Unidirectional (cardioid), rotationally symmetrical about microphone axis, uniform with frequency (see Figure 3)

Internal Connections

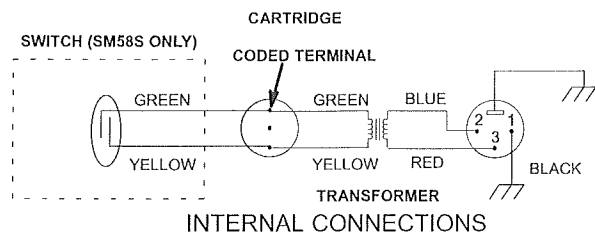

Overall Dimensions

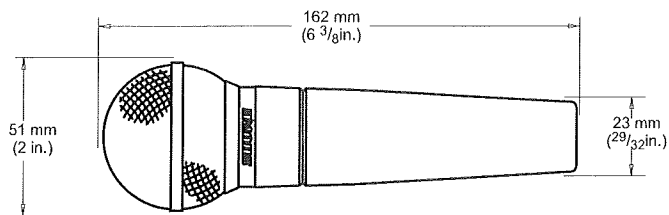

OVERALL DIMENSIONS

Connector

Three-pin professional audio connector (male XLR type)

Case

Dark gray, enamel-painted, die cast metal; matte-finished, silver colored, spherical steel mesh grille

Swivel Adapter

Positive-action, break-resistant, adjustable through 180°, with standard 5/8 in.-27 thread

Net Weight

298 grams (10.5 oz)

FURNISHED ACCESSORIES

- Swivel Stand Adapter A25D
- Storage Bag 26A13

REPLACEMENT PARTS

- Cartridge R59
- Screen and Grille Assembly RK143G

OPTIONAL ACCESSORIES

- Windscreen A58WS Series (8 colors available)
- Desk Stand S37A, S39A
- Isolation Mount A55M
- Dual Mount A26M
- Cable (7.6 m [25 ft]) C25E, C25F

ERK Series

enclosure

The ERK Series 19" welded stand-alone / gangable enclosures. Advanced manufacturing techniques provide highest quality and lowest price.

features:

- Fully welded construction
- 2,500 lb. weight capacity
- 1/8" thick structural steel internal braces
- UL Listed in the US and Canada
- Seismic certified (when used with ERK-Z4 option) with an Ip value of 1.5
- 22" OD width, available 20", 25" or 28" OD depth
- 1/2", 3/4", 1" & 1-1/2" electrical knockouts on removable split rear plates top and bottom, easily removable for cable pass-through. Top plates additionally include UHF / VHF knockouts
- Standard front, optional rear 11-gauge 10-32 threaded, fully adjustable rackrail with numbered rackspace increments
- Keylocked solid rear door standard, optional vented rear doors available
- Optional front doors available
- Configurable top options on 44, 40, and 35 space sizes
- Durable black textured powder coat finish

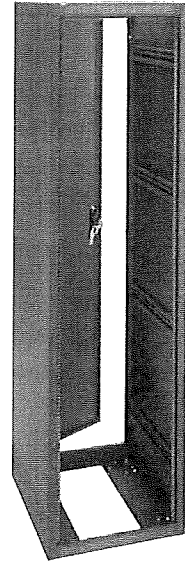

ERK-4425

specifications:

EIA compliant 19" stand-alone / gangable equipment rack shall be Middle Atlantic Products model # ERK-___-___(see chart for available models). Overall dimensions of rack shall be ___"H x ___"W x ___"D (refer to chart). Useable height shall be ___ rackspaces, useable depth shall be ___" (refer to chart). Rack shall be of fully welded construction. Weight capacity shall be 2,500 lbs. ERK shall be finished in a durable black powder coat. ERK shall come equipped with one pair of fully adjustable 11-gauge steel rackrail with tapped 10-32 mounting holes in universal EIA spacing, black e-coat finish and numbered rackspaces. ERK shall include solid locking rear door standard and solid sides with vertical slotted vent pattern at top and bottom (and laser knockouts for cable pass-through on 44, 40, and 35 space models). Top and bottom of ERK shall feature vertical slotted vent pattern. ERK shall have removable split rear knockout panels with 1/2", 3/4", 1", and 1-1/2" electrical knockouts installed in base and a removable rear knockout panel with 1/2", 3/4", 1", and 1-1/2" electrical knockouts and BNC knockouts for UHF/VHF antennae installed in top. Grounding and bonding stud shall be 1/4-20 threaded (1 location), bonding stud shall be 10-32 threaded (3 locations). ERK Series enclosures shall satisfy the 2005 & 2010 Editions of ASCE Standard 7; 2006, 2009 & 2012 editions of the IBC; 2007, 2010 & 2013 editions of the CBC; 2010 editions of the NBC and 2012 edition of the BCBC for use in areas of high seismicity, Occupancy Category IV facilities. Seismic design force is an assumed Site Class D soil conditions, and top floor or rooftop installations. Design for High Importance or Post-disaster installation uses an importance factor (Ip or Ie) of 1.5 when used with ERK-Z4 seismic floor anchor bracket. ERK shall be UL Listed in the US to UL2416 (NWIN) and Canada to CSA C22.2 No. 60950-1. ERK shall be GREENGUARD Gold Certified. ERK Series shall meet the RoHS EU Directive 2011/65/EU. ERK shall be manufactured by an ISO 9001 and ISO 14001 registered company. ERK shall be warranted to be free from defects in material or workmanship under normal use and conditions for the lifetime of the product.

Customizable specification clips available at middleatlantic.com



PRODUCT CERTIFIED FOR LOW CHEMICAL EMISSIONS
UL.COM/GG
UL 2818



options:

- Front doors shall be model #FD-XX (solid), VFD-XX (vented, 22% open area), LVFD-xx (vented 63% open area-not available for 27 space rack) PVFD-44 (vented plexi), (X=# of rackspaces of ERK rack)
- Rear door, vented, shall be ERK-VRD-XX, Cable management shall be ERK-RDC-XX (XX= # of rackspaces of ERK Rack)
- Top panels for 35, 40 or 44 space ERK, multiple styles available including model #ERK-ST (solid), ERK-10FT (10" fan), ERK-6FT (two 6" fans) ERK-4FT (three 4-1/2" fans), ERK-VT (vented) and ERK-LVT (large perf vented) see A&E spec 96-01063 for more details
- Caster base, four casters shall have a total weight capacity of 1300 pounds, model # CBS-ERK-YY (Y= cabinet depth), raises racks 3.9" (commercial grade) or 4.1" (fine floor)
- Rear rail kit, 11-gauge, 10-32 threaded, sold in pairs, hardware included, model #ERK-RRXX (X=# of rackspaces)
- Seismic compliancy floor anchor kit, model # ERK-Z4
- 18, 21 and 27 space ERK come preconfigured with solid top that includes knockouts to accommodate up to two 4-1/2" fans, or included vent panels
- Optional bonding kit for UL-2416 (NWIN) compliance shall be PET-K-RD (for rear door to enclosure), PET-K-RDC (for cable management rear door to enclosure), PET-K-EXT (for extender bay to enclosure)
- Extender bay adds 3" of usable depth, front mount shall be ERK-(44, 40)-F-EXT3, rear shall be ERK-(44,40)-R-EXT3
- Grommet for 4" electrical knockout in side of ERK shall be model # GK4 and include 4 pieces
- Gland grommet for 4" electrical knockout in side of ERK shall be model #GK-4G. 4 Pieces.
- Slide out option available (See AXS Spec sheet 96-055S)

what great systems are built on.™

A brand of Legrand



Middle Atlantic Products
middleatlantic.com | middleatlantic.com

ERK Series

configured A/V enclosure

Configured A/V enclosure ships complete with the most commonly used accessories.

features:

- Integrated fan top
- Configurable rear door with bottom vent, solid locking front door
- 3-1/4" wide vertical lacer strip (height varies based on model)
- Six horizontal lacer bars
- Twelve 8" Velcro® cable management straps
- Thin power strip, 20 Amp, 20 outlet with cord (44 space enclosures) or 2 qty. thin power strip, 20 Amp, 10 outlet with cord (35 & 40 space enclosures)
- Leveling feet
- 100 qty. 10-32 mounting hardware

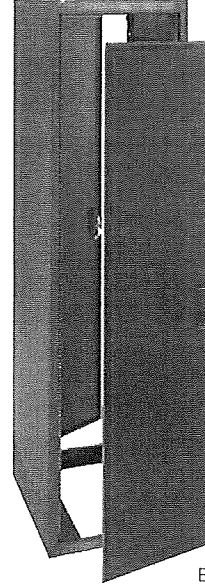

ERK-4425-AV

specifications:

EIA compliant 19" stand-alone / gangable equipment rack shall be Middle Atlantic Products model # ERK-___-AV(see chart for available models). Overall dimensions of rack shall be ___"H x ___"W x 25"D (refer to chart). Useable height shall be ___ rackspaces, useable depth shall be 23-1/2". Rack shall be of fully welded construction. Weight capacity shall be 2,500 lbs. ERK shall be finished in a durable black powder coat. Solid front door and vented, locking and latching rear door and all structural elements shall be finished in a durable black powder coat. Rack shall come equipped with two pairs of 11-gauge steel rackrail with tapped 10-32 mounting holes in universal EIA spacing, black e-coat finish and numbered rackspaces. Rack shall include 100 qty. 10-32 mounting screws. Rack shall be equipped with one 3-1/4" vertical lacer strip Middle Atlantic Products model # LACE-___-OP (refer to chart), four 'L' shaped straight and two 4" offset horizontal lacer bars and twelve, 8" Velcro® straps for cable management. The ERK shall have a solid locking rear door standard and solid side panels with vertical slotted vent pattern at top and bottom with laser knockouts for cable pass-through. Rack shall have feature integrated fan top, Middle Atlantic Products model # ERK-4FT-285CFM for active thermal management. The ERK-4FT-285CFM shall consist of three 4-1/2" fans and airflow shall be 285 CFM. Rack shall have removable split rear knockout panels with 1/2", 3/4", 1" and 1-1/2" electrical knockouts and top BNC knockouts for UHF/VHF antennae. Grounding and bonding stud shall be 1/4-20 threaded (1 location), bonding stud shall be 10-32 threaded (3 locations). ERK Series enclosures shall satisfy the 2005 & 2010 Editions of ASCE Standard 7; 2006, 2009 & 2012 editions of the IBC; 2007, 2010 & 2013 editions of the CBC; 2010 editions of the NBC and 2012 edition of the BCBC for use in areas of high seismicity, Occupancy Category IV facilities. Seismic design force is an assumed Site Class D soil conditions, and top floor or rooftop installations. Design for High Importance or Post-disaster installation uses an importance factor (I_p or I_e) of 1.5 when used with ERK-Z4 seismic floor anchor bracket. . ERK-___-AV shall include a high-density thin power distribution and shall be Middle Atlantic Products model # PDT-___-NS with ___ outlets and 20 amps (refer to chart). Thin power distribution shall be ___" long (refer to chart) x 1" deep x 1.9" wide. J-Box shall be 2" deep x 2" wide. Thin power distribution shall feature ___ NEMA 5-20R outlets. Corded power strip includes 20 amp protection and mounting hardware. Corded model shall be terminated with 10-foot power cord and a NEMA 5-20P plug. PDT Series shall feature a black anodized finish. ERK shall be UL Listed in the US to UL2416 (NWIN) and Canada to CSA C22.2 No. 60950-1. ERK shall be GREENGUARD Gold Certified. ERK shall be RoHS EU Directive 2002/95/EC and 2011/65/EU compliant. ERK shall be manufactured by an ISO 9001 and ISO 14001 registered company. ERK shall be warrantied to be free from defects in material or workmanship under normal use and conditions for the lifetime of the product.

Customizable specification clips available at middleatlantic.com



PRODUCT CERTIFIED FOR
LOW CHEMICAL EMISSIONS
UL.COM/GG
UL 2818



PEP
PASS
PORT®

what great systems are built on.™

ERK Series

basic dimensions

all dimensions in inches unless otherwise noted [all dimensions in brackets are in millimeters]

top view of ERK side sectional view

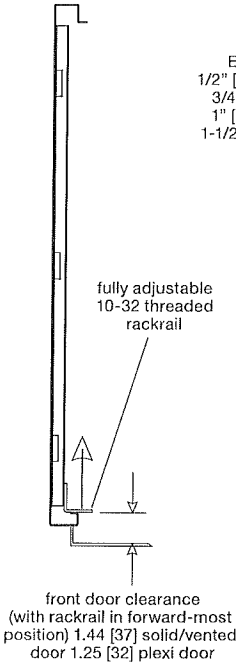

rear view

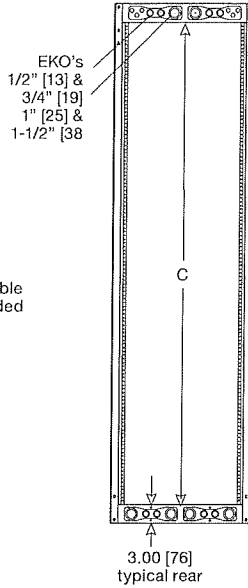

side view

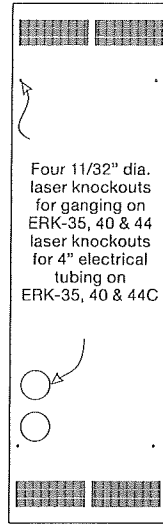

front view

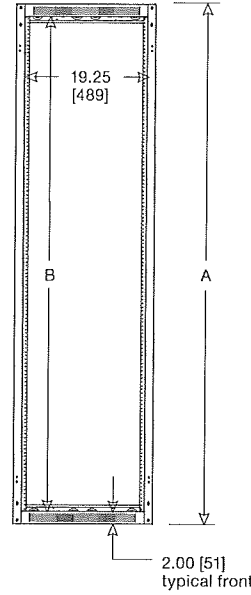

top view ERK-18XX / ERK-21XX / ERK-27XX

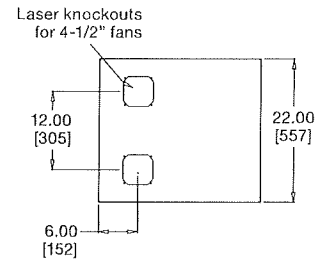

top view ERK-35XX / ERK-40XX / ERK-44XX

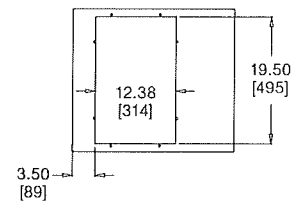

bottom view mounting holes

ERK-XX20=17.93 [456]
ERK-XX25=22.93 [583]
ERK-XX28=25.93 [659]

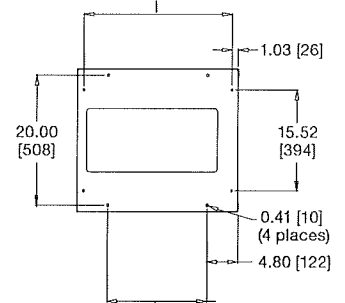

ERK-XX20=10.41 [264]
ERK-XX25=15.41 [391]
ERK-XX28=18.41 [468]

rear view

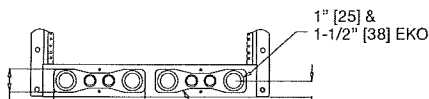
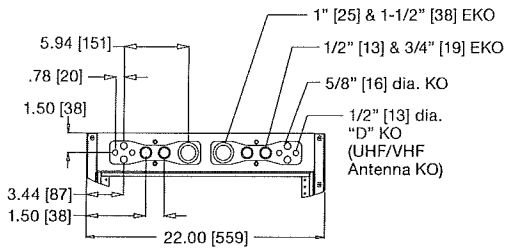

bottom view

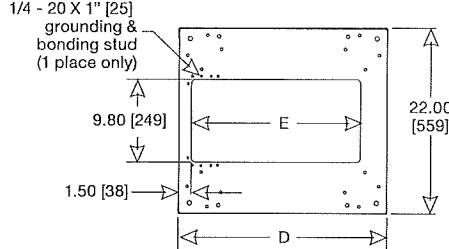

what great systems are built on.™

A brand of Legrand

Middle Atlantic Products

middleatlantic.com | middleatlantic.com

ERK Series

basic dimensions

all dimensions in inches unless otherwise noted [all dimensions in brackets are in millimeters]

Part #	A Overall Height	B Useable Height	C Rear Height	D Overall Depth	E Bottom Opening Depth	Useable Depth
ERK-4428	81.130 [2061]	77.130 [1959]	75.130 [1908]	28.00 [711]	23.25 [591]	26.47 [672]
ERK-4028	74.130 [1883]	70.130 [1781]	68.130 [1731]	28.00 [711]	23.25 [591]	26.47 [672]
ERK-3528	65.380 [1661]	61.380 [1559]	59.380 [1508]	28.00 [711]	23.25 [591]	26.47 [672]
ERK-2728	51.380 [1305]	47.380 [1203]	45.380 [1153]	28.00 [711]	23.25 [591]	26.47 [672]
ERK-2128	40.880 [1038]	36.880 [937]	34.880 [886]	28.00 [711]	23.25 [591]	26.47 [672]
ERK-1828	35.630 [905]	31.630 [803]	29.630 [753]	28.00 [711]	23.25 [591]	26.47 [672]
ERK-4425	81.125 [2061]	77.125 [1959]	75.125 [1908]	25.00 [635]	20.25 [514]	23.47 [596]
ERK-4025	74.125 [1883]	70.125 [1781]	68.125 [1703]	25.00 [635]	20.25 [514]	23.47 [596]
ERK-3525	65.375 [1661]	61.375 [1559]	59.375 [1508]	25.00 [635]	20.25 [514]	23.47 [596]
ERK-2725	51.375 [1305]	47.375 [1203]	45.375 [1153]	25.00 [635]	20.25 [514]	23.47 [596]
ERK-2125	40.875 [1038]	36.875 [937]	34.875 [886]	25.00 [635]	20.25 [514]	23.47 [596]
ERK-1825	35.625 [905]	31.625 [803]	29.625 [752]	25.00 [635]	20.25 [514]	23.47 [596]
ERK-4420	81.125 [2061]	77.125 [1959]	75.125 [1908]	20.00 [508]	15.25 [387]	18.47 [469]
ERK-4020	74.125 [1883]	70.125 [1781]	68.125 [1703]	20.00 [508]	15.25 [387]	18.47 [469]
ERK-3520	65.375 [1661]	61.375 [1559]	59.375 [1508]	20.00 [508]	15.25 [387]	18.47 [469]
ERK-2720	51.375 [1305]	47.375 [1203]	45.375 [1153]	20.00 [508]	15.25 [387]	18.47 [469]
ERK-2120	40.875 [1038]	36.875 [937]	34.875 [886]	20.00 [508]	15.25 [387]	18.47 [469]
ERK-1820	35.625 [905]	31.625 [803]	29.625 [752]	20.00 [508]	15.25 [387]	18.47 [469]
ERK-4425-AV	81.125 [2061]	77.125 [1959]	75.125 [1908]	25.00 [635]	20.25 [514]	23.47 [596]
ERK-4025-AV	74.125 [1883]	70.125 [1781]	68.125 [1703]	25.00 [635]	20.25 [514]	23.47 [596]
ERK-3525-AV	65.375 [1661]	61.375 [1559]	59.375 [1508]	25.00 [635]	20.25 [514]	23.47 [596]

top view (35, 40, and 44 space only)

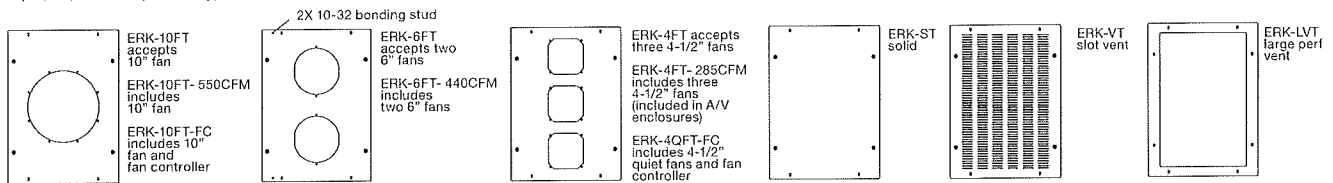

ERK A/V Enclosure Power Distribution

Rack Part #	Part #	Terminated	Circuit	Outlets	Overall Length	Qty
ERK-4025-AV / ERK-3525-AV	PDT-1020C-NS 5-20P	20 Amp	10, 5-20R	37.75 [959]	2	26.47 [672]
ERK-4425-AV	PDT-2020C-NS 5-20P	20 Amp	20, 5-20R	72.75 [1848]	1	23.47 [596]

ERK A/V Enclosure Vertical Lacer Bar Chart

Part #	Lacer Bar	# of Rackspace	Width
ERK-4425-AV	LACE-44-OP	44	3.25 [83]
ERK-4025-AV	LACE-40-OP	40	3.25 [83]
ERK-3525-AV	LACE-37-OP	37	3.25 [83]

what great systems are built on.™

A brand of Legrand

Middle Atlantic Products

middleatlantic.com | middleatlantic.ca

ERK Series

basic dimensions

all dimensions in inches unless otherwise noted [all dimensions in brackets are in millimeters]

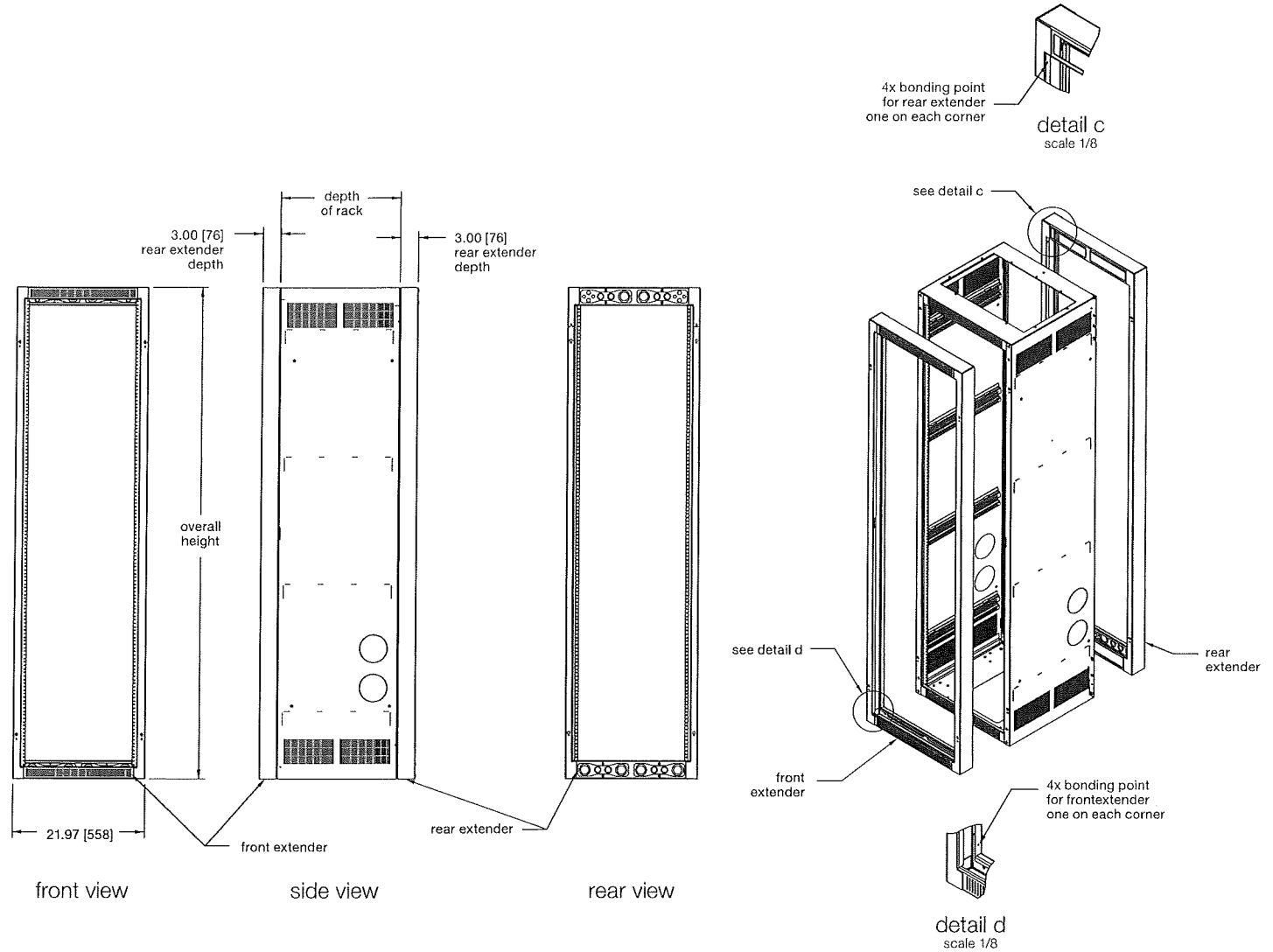

Part #	Rackspaces	Overall Height	Used On	Mounting Location
ERK-44-F-EXT3	44	81.13 [2061]	ERK-44XX	front
ERK-44-R-EXT3	44	81.13 [2061]	ERK-44XX	rear
ERK-40-F-EXT3	40	74.13 [1883]	ERK-40XX	front
ERK-40-R-EXT3	40	74.13 [1883]	ERK-40XX	rear

what **great systems** are built on.™

A brand of  Legrand



Middle Atlantic Products
middleatlantic.com | middleatlantic.ca

ERK Series

basic dimensions

all dimensions in inches unless otherwise noted [all dimensions in brackets are in millimeters]

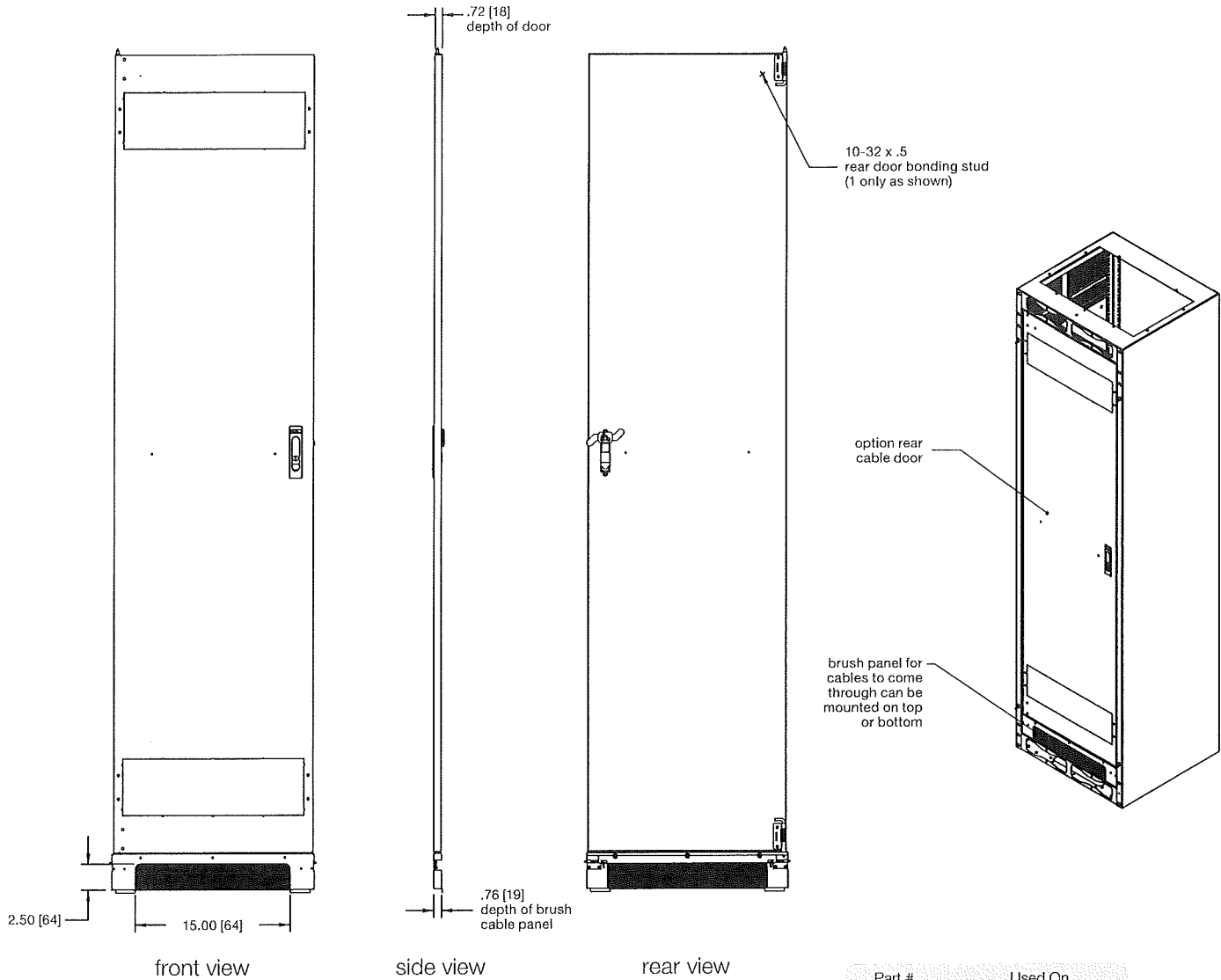

Part #	Used On
ERK-RDC18	ERK-18XX
ERK-RDC21	ERK-21XX
ERK-RDC27	ERK-27XX
ERK-RDC35	ERK-35XX
ERK-RDC40	ERK-40XX
ERK-RDC44	ERK-44XX

NOTE: Brush panel can be mounted on top or bottom of rack

what **great systems** are built on.™

A brand of  Legrand



Middle Atlantic Products

middleatlantic.com | middleatlantic.ca

UD Series

UTILITY DRAWERS

the UD series rackmount utility drawers offer an economical storage solution for any enclosure

FEATURES:

- Full extension ball bearing slides extend a full 14"
- Durable black powder coat finish
- Keylock and latch option for security, user-installed (2, 3 and 4 space drawers only)
- Cable entry point at the rear of the drawer allows for optimized cable management
- Four sizes available
- UL Listed in the US and Canada

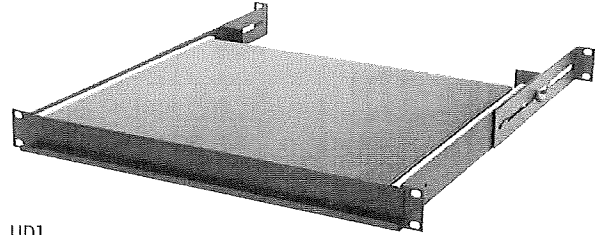

UD1
(shown as a writing surface)

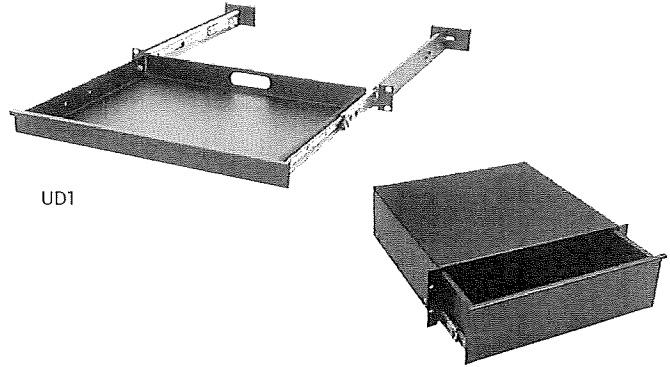

UD1

UD3

SPECIFICATIONS:

EIA compliant 19" rackmount drawer shall be Middle Atlantic Products model # UD_ (refer to chart). Drawer shall have useable width of __", a useable surface of __" and occupy __ rackspaces (refer to chart). Drawer base shall be __-gauge steel, top and sides shall be __-gauge steel (refer to chart). Drawer faceplate shall be __-gauge steel with a black powder coat finish (refer to chart). Drawer shall extend __" (refer to chart). Drawer shall use full extension, ball bearing slides. UD_ shall have cable entry point at the rear of the drawer. UD_ shall have a knockout on the face of the drawer to accommodate optional user-installed latch and keylock (refer to chart). Drawer shall have mounting hole spacing of __" (refer to chart). Drawer shall have a 50 lb. weight capacity. Drawer shall be UL Listed in the US and Canada. Drawer shall be RoHS EU Directive 2011/65/EU compliant. Drawer shall be manufactured by an ISO 9001 and ISO 14001 registered company. Drawer shall be warranted to be free from defects in materials or workmanship under normal use and conditions for a period of three years.

Customizable specification clips available at middleatlantic.com

EIA/TIA COMPLIANT



OPTIONS:

- User installed latch for UD Series drawers shall be Middle Atlantic Products model # LATCH. LATCH shall fit 2, 3 and 4 space drawers.
- User installed keylock for UD Series drawers shall be Middle Atlantic Products model # KYLK. KYLK shall fit 2, 3 and 4 space drawers.
- Additional set of keys for KYLK shall be Middle Atlantic Products model # ACC-KEY.
- No-slip drawer mat for UD Series drawers shall be Middle Atlantic Products model #DM.

WHAT GREAT SYSTEMS ARE BUILT ON.™

A brand of Legrand

Middle Atlantic Products
middleatlantic.com | middleatlantic.ca

96-01105 / rev b / 9-6-17

UD Series Utility Drawers

BASIC DIMENSIONS

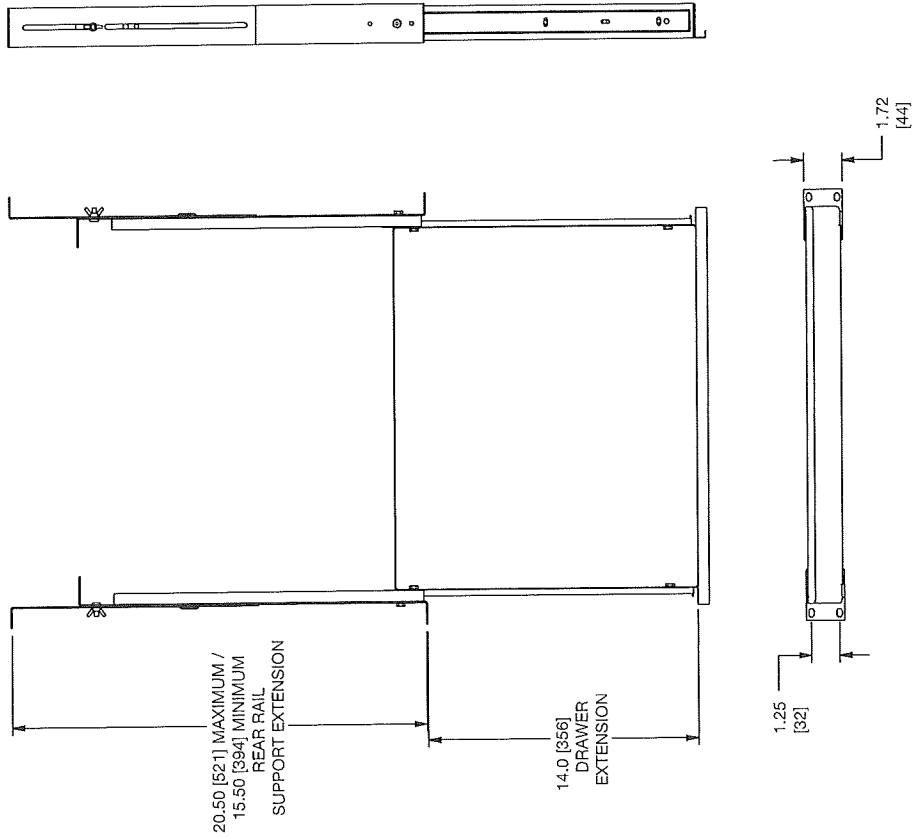
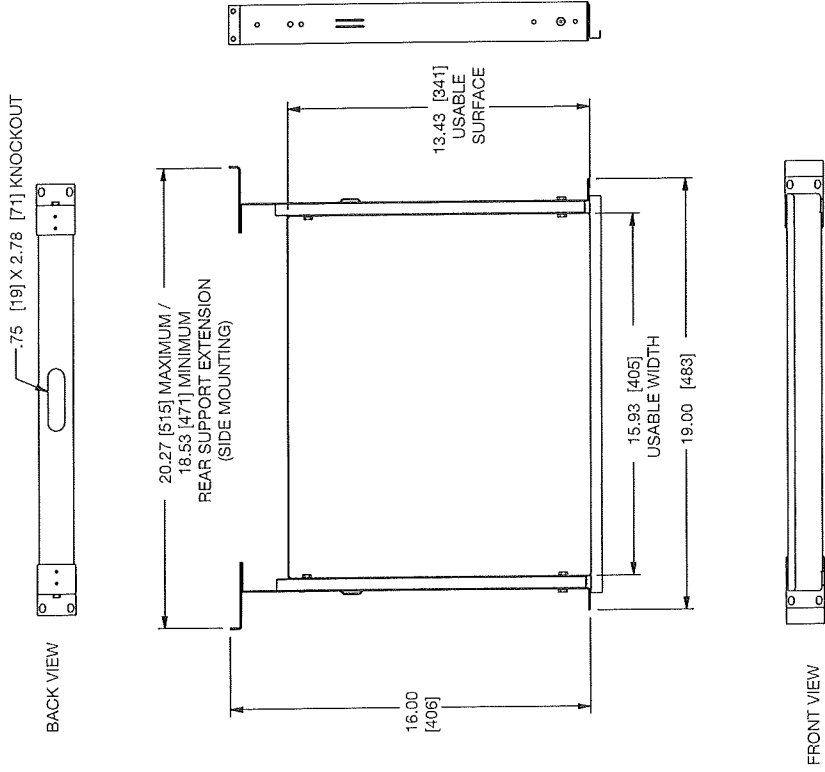

WHAT GREAT SYSTEMS ARE BUILT ON.™

A brand of  Legrand



Middle Atlantic Products
middleatlantic.com | middleatlantic.ca



UD Series Utility Drawers

BASIC DIMENSIONS

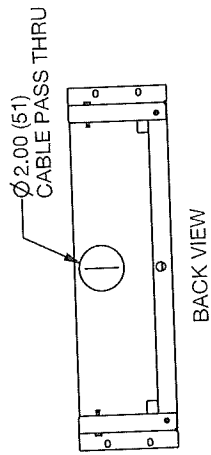

BACK VIEW

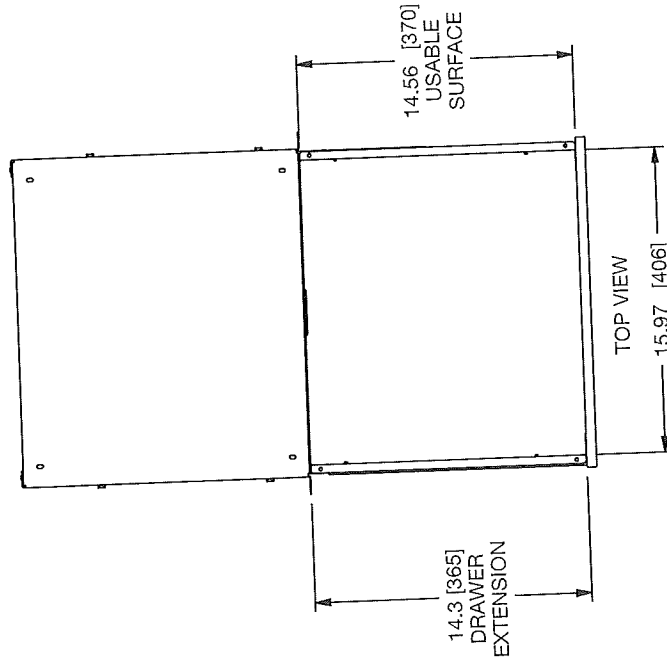
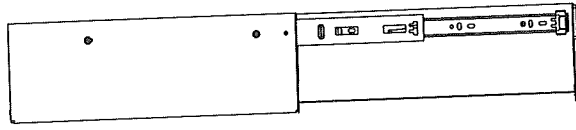

	"A" HEIGHT	"B" MOUNTING HOLE SPACING
UD2	3.50 [89]	3.00 [76]
UD3	5.25 [133]	2.25 [57]
UD4	7.00 [178]	4.00 [102]

R SERIES
 Point Source

R.35COAX

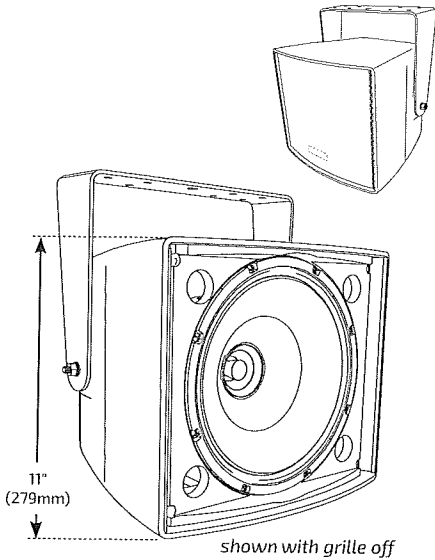
 TWO-WAY 10-INCH COAXIAL
 WEATHER-RESISTANT LOUDSPEAKER

FEATURES

- Excellent musicality and intelligibility, and low distortion in an extremely compact enclosure
- Weather-resistant, compact, matte finish paintable high impact ABS plastic modified-trapezoidal enclosure
- Hydrophobically-treated grille and LF driver cone, polymer HF diaphragm, and moisture-sealed crossover
- 200W Autoformer (standard), selectable 8 ohm or 70V/100V operation
- Corrosion-resistant dual-layer powder-coated low-profile steel yoke and aluminum grille

TECHNICAL SPECIFICATIONS¹

Operating Mode	Passive, Selectable Low Impedance or 70V/100V				
Operating Environment	Indoor or Weather-Resistant Outdoor				
Operating Range ²	70 Hz to 16 kHz				
Nominal Beamwidth (H x V)	90° x 90°				
Transducers	LF 1 x 10" (254mm) Carbon ring cone with hydrophobic treatment, 2" (51mm) Voice Coil HF 1 x 1.25" (32mm) exit compression				
Continuous Power Handling ³ @ Nominal Impedance	Passive	40V	200W @ 8 Ohms (800W peak)		
Autoformer Taps	70V: 200W, 100W, 50W, 25W 100V: 200W, 100W, 50W				

		MUSIC		VOICE	
Nominal Sensitivity ⁴	Passive	@ 1W 97 dB	@ 2.83V 97 dB	@ 1W 99 dB	@ 2.83V 99 dB
Nominal Maximum SPL ⁵ (Whole Space)	Passive	Peak 126 dB	Continuous 120 dB	Peak 128 dB	Continuous 122 dB
Equalized Sensitivity ⁶	System	@ 1W 97 dB	@ 2.83V 97 dB		
Equalized Maximum SPL ⁷	System	Peak 126 dB	Continuous 120 dB		

Required Accessories	High Pass Filter - 70 Hz, 24 dB /octave, Digital Signal Processor				
Recommended Amplifiers	Passive	200W - 400W @ 8 Ohms, (40V - 57V)			

PHYSICAL

Input Connection	NL4 Speakon-type connector (low impedance only), and 7-position terminal strip for low impedance or constant voltage operation				
Controls	Music / Voice switch, 70V/100V operation jumper				
Mounting Points	Two (2) M8 rigging points				
Included Accessories	Zinc-rich epoxy dual-layer powder-coated yoke, included integral safety cable mounting point				
Environmental	IP55W per IEC 529, designed to MIL-STD-810G Color-matched ABS plastic input panel weather cover with 13.5mm ID gland nut installed in .82" knockout				
Dimensions H x W x D	11.00" x 13.00" x 13.50" (279 x 330 x 343 mm)				
Weight	26 lbs (11.8 kg) with included yoke				
Finish	Refer to the Technical Drawing (page 3)				

OPTIONS

Accessories	R-VTY35: Provides pan-tilt aiming functions. Zinc-rich dual-layer powder-coated steel with SS hardware, color-matched to loudspeaker. R-FRY35: Provides full rotation mounting capability for down-firing application (i.e. top of press box). Zinc-rich epoxy dual-layer powder-coated steel with SS hardware, color-matched to loudspeaker				
-------------	---	--	--	--	--

APPLICATIONS

Theme and Amusement Parks · Malls · Stadiums
 Fairgrounds · Outdoor Entertainment Centers
 Race Tracks · Athletic Fields · Swimming Pools
 Background Music / Voice Paging Systems
 Convention Centers · Factories
 Multipurpose outdoor and indoor venues

DESCRIPTION

The R.35COAX is a two-way, full-range loudspeaker system designed to provide high quality voice and music reproduction in applications requiring extreme weather resistance. It is designed to withstand long-term exposure to tough, environmental conditions and to provide performance normally associated only with indoor loudspeakers. The R.35COAX has a 1.25-inch (32mm) exit HF compression driver and a 10-inch (254mm) cone LF driver with a 2-inch voice coil. The HF assembly is coaxially mounted with the LF driver allowing 90° conical coverage with low distortion. The carbon ring cone design provides a cone area nearly equivalent to a typical 12-inch driver cone.

The Music / Voice switch provides an out-of-the-box selectable flat response or 3dB boost for increased vocal intelligibility allowing for additional application flexibility. The design uses Community's proprietary Tru-Phase™ high frequency compression driver phase plug to provide wide dispersion, low distortion and increased intelligibility. The LF driver cone is treated with the same hydrophobic protection as the grille cloth to provide full weather-resistance. The enclosure has a reinforced ribbed interior with weather-treated wooden inserts to reduce resonance, increase rigidity and reduce rear and lateral radiation. The R.35COAX carries a 5 year product warranty and a 15 year enclosure warranty.

R.35COAX TWO-WAY 10-INCH COAXIAL WEATHER-RESISTANT LOUDSPEAKER

AXIAL PROCESSED RESPONSE (dB)⁸

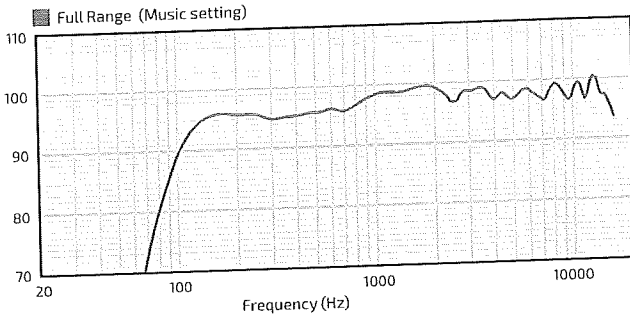

BEAMWIDTH (Degrees)¹²

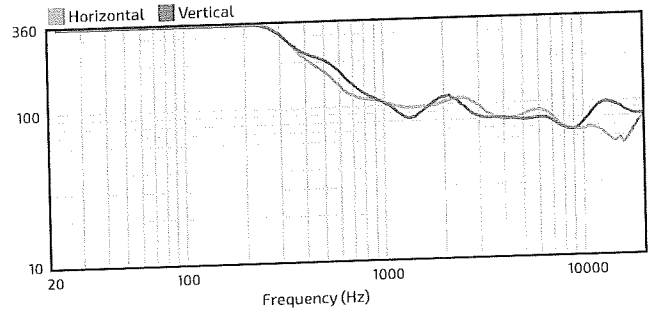

AXIAL SENSITIVITY (dB SPL)⁹

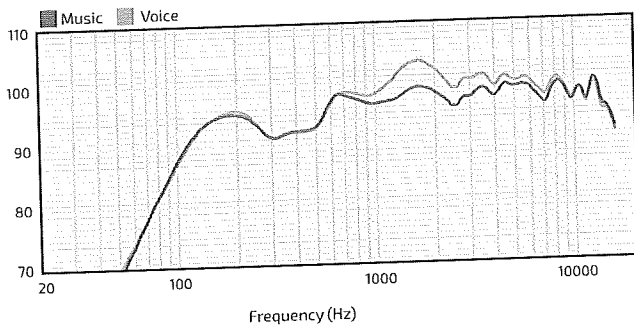

DIRECTIVITY INDEX (dB)¹¹

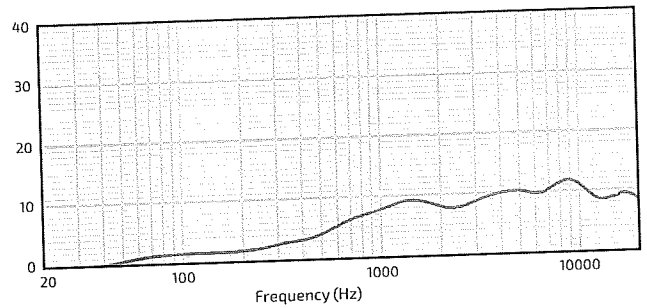

IMPEDANCE (Ohms)

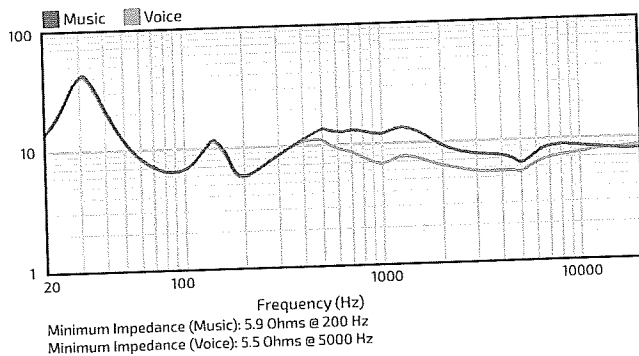

ARCHITECTURAL SPECIFICATIONS

The loudspeaker system shall be a two-way, full-range modified trapezoidal design with one 10-inch (254mm) high-output LF driver and one 1.25-inch (32mm) exit HF driver mounted coaxially. Drivers shall be connected to an integral crossover with a crossover frequency of 1.3 kHz. The input connections shall be an NL4-type connector and a 7-position terminal strip for standard or autoformer tap operation. There is also a 2-position switch for voice or music applications. The system shall be equipped with a 200W high performance autoformer for use in 70.7V or 100V distributed audio systems, with 200W, 100W, 50W and 25W taps available in 70.7V distributed systems (200W, 100W and 50W taps available in 100V distributed systems). The loudspeaker enclosure shall be matte finish high impact ABS plastic with a 1mm perforated aluminum grille backed by hydrophobically-treated polyester mesh and open cell foam. There shall be two M8 rigging points, and an included dual-layer zinc-rich epoxy powder-coated steel mounting yoke. Integrated ribbing and internal reinforcements provide added structural support. The system shall have an operating range of 70 Hz to 16 kHz (-10 dB) and a low impedance (8 Ohm) input capability of 40V RMS. At the "Music" setting, it shall have a sensitivity on axis at 1W / 1m, 8 ohms nominal impedance, of 97 dB. At the "Voice" setting, it shall have a sensitivity at 1W / 1m, 8 ohms nominal impedance, of 99 dB. The nominal dispersion shall be 90° H x 90° V. The loudspeaker shall be 11" (279mm) H (front) x 13" (330mm) W x 13.5" (343mm) D and shall weigh 26 lbs (11.8 kg) with the included mounting yoke.

R SERIES Point Source

R.35COAX

TWO-WAY 10-INCH COAXIAL
WEATHER-RESISTANT LOUDSPEAKER

CONNECTION DIAGRAM

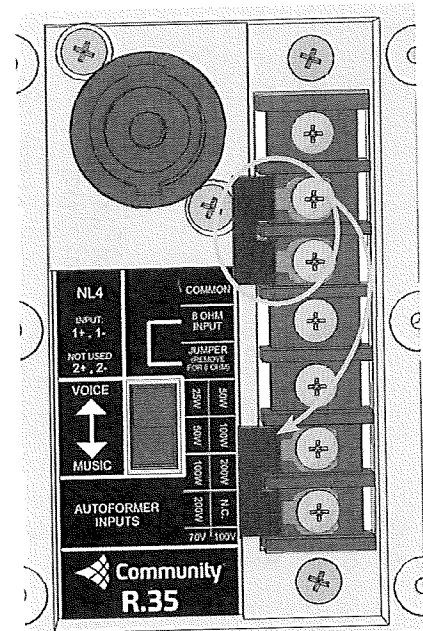
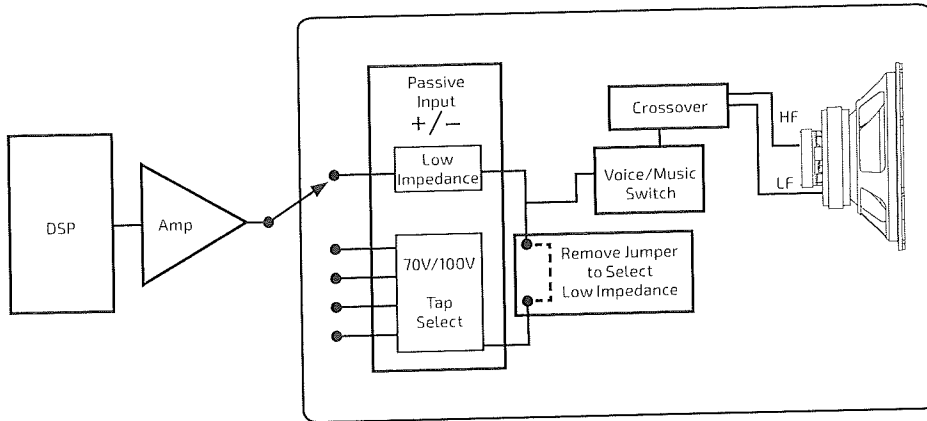

Must remove jumper, or move it to the bottom terminals, for 8Ω operation (see yellow arrow)

Input panel

NOTES

- PERFORMANCE SPECIFICATIONS** All measurements are taken indoor using a time-windowed and processed signal to eliminate room effects, approximating an anechoic environment, a distance of 5.0 m. All acoustic specifications are rounded to the nearest whole number. An external DSP with settings provided by Community Professional Loudspeakers is required to achieve the specified performance; further performance gains can be realized using Community's dSPEC226 loudspeaker processor with FIR power response optimization.
- OPERATING RANGE** The frequency range in which the on-axis processed response remains within 10dB of the average SPL.
- CONTINUOUS POWER HANDLING** Maximum continuous input voltage (and the equivalent power rating, in watts, at the stated nominal impedance) that the system can withstand, without damage, for a period of 2 hours using an EIA-426-B defined spectrum; with recommended signal processing and protection filters.
- NOMINAL SENSITIVITY** Averaged SPL over the operating range with an input voltage that would produce 1 Watt at the nominal impedance and the averaged SPL over the operating range with a fixed input voltage of 2.83V, respectively; swept sine wave axial measurements with no external processing applied in whole space, except where indicated.
- NOMINAL MAXIMUM SPL** Calculated based on nominal / peak power handling, respectively, and nominal sensitivity; exclusive of power compression.
- EQUALIZED SENSITIVITY** The respective SPL levels produced when an EIA-426-B signal is applied to the equalized loudspeaker system at a level which produces a total power of 1 Watt, in sum, to the loudspeaker subsections and also at a level which produces a total voltage, in sum, of 2.83V to the loudspeaker subsections, respectively; each referenced to a distance of 1 meter.
- EQUALIZED MAXIMUM SPL** The SPL produced when an EIA-426-B signal is applied to the equalized loudspeaker system, at a level which drives at least one subsection to its rated continuous input voltage limit, referenced to a distance of 1 meter. The peak SPL represents the 2:1 (6dB) crest factor of the EIA-426-B test signal.
- AXIAL PROCESSED RESPONSE** The on-axis variation in acoustic output level with frequency of the complete loudspeaker system with recommended signal processing applied. 1/6 octave Gaussian smoothing applied.
- AXIAL SENSITIVITY** The on-axis variation in acoustic output level with frequency for a 1 Watt swept sine wave, referenced to 1 meter with no signal processing. 1/6 octave Gaussian smoothing applied.
- HORIZONTAL / VERTICAL OFF-AXIS RESPONSES** The loudspeaker's magnitude response at various angles off-axis, with recommended signal processing applied in the operating mode which utilizes the largest number of individually amplified pass bands. 1/6 octave Gaussian smoothing applied.
- DIRECTIVITY INDEX** The ratio of the on-axis SPL squared to the mean squared SPL at the same distance for all points within the measurement sphere for each given frequency; expressed in dB. 1/6 octave Gaussian smoothing applied.
- BEAMWIDTH** The angle between the -6dB points in the polar response of the loudspeaker when driven in the operating mode which utilizes the largest number of individually amplified pass bands. 1/6 octave Gaussian smoothing applied.

Data presented on this spec sheet represents a selection of the basic performance specifications for the R.15COAX. These specifications are intended to allow the user to perform a fair, straightforward evaluation and comparison with other loudspeaker spec sheets. For a detailed analysis of this loudspeaker's performance, please download the GLL file and/or the CLF file from our website: communitypro.com

CAUTION: Installation of loudspeakers should only be performed by trained and qualified personnel. It is strongly recommended that a licensed and certified professional structural engineer approve the mounting design.