

AIA[®] Document G701[™] – 2017

Change Order

PROJECT: <i>(Name and address)</i> New Hampton CSD 5-6/7-8 Middle School & High School Additions at the existing HS Facility New Hampton, IA	CONTRACT INFORMATION: Contract For: General Construction Date: 11-28-17	CHANGE ORDER INFORMATION: Change Order Number: GC CO03 Date: 7-24-18
OWNER: <i>(Name and address)</i> Hew Hampton CSD 710 West Main New Hampton, IA 50659	ARCHITECT: <i>(Name and address)</i> Facilities Cost Management Group, LLC 406 South 12th Street, Ste 300 Omaha, NE 68102	CONTRACTOR: <i>(Name and address)</i> Cresco Building Service, Inc. 521 2nd Ave Cresco, IA 52136

THE CONTRACT IS CHANGED AS FOLLOWS:

(Insert a detailed description of the change and, if applicable, attach or reference specific exhibits. Also include agreed upon adjustments attributable to executed Construction Change Directives.)

1. Add for lengthening Joist Tails [RFI #6/PR-6]	\$ 1,150.00
2. Add for adding 6x6 tee, connecting storm sewer, 12" HDPE	\$ 6,669.00
3. Add to replace uncovered intake structure in the south area	\$ 3,651.00
4. Add for Stl Lintel at Alcove 601 - Load Bearing [RFI#15/COR12]	\$ 2,231.00
5. Add for Fire Marshal Approved Ceiling at Corridor 702 [COR 13]	\$ 5,754.00
6. Add for Fire Marshal Review Changes at Dr Opngs & HDW	\$ 9,066.00
Total of this Change Order	\$ 28,521.00

The original Contract Sum was	\$ 8,559,094.00
The net change by previously authorized Change Orders	\$ 310,583.00
The Contract Sum prior to this Change Order was	\$ 8,869,677.00
The Contract Sum will be increased by this Change Order in the amount of	\$ 28,521.00
The new Contract Sum including this Change Order will be	\$ 8,898,198.00
The Contract Time will be increased by Zero (0) days.	
The new date of Substantial Completion will be	

NOTE: This Change Order does not include adjustments to the Contract Sum or Guaranteed Maximum Price, or the Contract Time, that have been authorized by Construction Change Directive until the cost and time have been agreed upon by both the Owner and Contractor, in which case a Change Order is executed to supersede the Construction Change Directive.

NOT VALID UNTIL SIGNED BY THE ARCHITECT, CONTRACTOR AND OWNER.

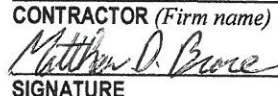
<u>Facilities Cost Management Group, LLC</u> ARCHITECT <i>(Firm name)</i>	<u>Cresco Building Service, Inc.</u> CONTRACTOR <i>(Firm name)</i>	<u>New Hampton CSD</u> OWNER <i>(Firm name)</i>
 SIGNATURE	 SIGNATURE	 SIGNATURE
Annette J. Zeplin, Proj. Mgr. PRINTED NAME AND TITLE	Matthew D. Brace, Sec-Treas. PRINTED NAME AND TITLE	 PRINTED NAME AND TITLE
7-24-18 DATE	10-8-18 DATE	 DATE

Approved

CRESCO BUILDING SERVICE INC.

GENERAL CONTRACTOR
CONSTRUCTION MANAGEMENT

521 2nd Avenue SW; P.O. Box 88

Cresco, IA 52136

Phone 563.547.2525 - Fax 563-547-2256

E-mail: matt@crescobuildingservice.com

Website: www.crescobuildingservice.com



Authorized Dealer of Varco Pruden Pre-Engineered Steel Buildings

Change Proposal Request #6

Relating To: Legthening Joist Tails

Reference: RFI #6

DATE: 5-22-18

PROJECT: New Hampton CSD Middle/High School Additions

OWNER: New Hampton Community School District

ARCHITECT: Purdy & Slack (Dean Mitchell)

Grosse Steel (Vulcraft)= \$1000 (As per email 3-15-18)

CBS OH & P= \$150

Total= \$1150

Matt Brace

Cresco Building Service

521 2nd Ave SW

PO Box 88

Cresco IA 52136

563- 547- 2525

563- 547- 2256 FAX

641-220-4403 CELL

matt@crescobuildingservice.com

Approved

CRESKO BUILDING SERVICE INC.

**GENERAL CONTRACTOR
CONSTRUCTION MANAGEMENT**

521 2nd Avenue SW; P.O. Box 88

Cresco, IA 52136

Phone 563.547.2525 - Fax 563-547-2256

E-mail: matt@crescobuildingservice.biz

Website: www.crescobuildingservice.com



Authorized Dealer of Varco Pruden Pre-Engineered Steel Buildings

Change Proposal Request #09

Relating To:

RFI #11 Intake Structure (Question 7)

DATE: 6-18-18

PROJECT: New Hampton CSD Middle/High School Additions

OWNER: New Hampton Community School District

ARCHITECT: Purdy & Slack (Dean Mitchell)

Bruening= \$3,175

CBS OH&P= \$476

Total= \$3,651

See attached sheets for breakdown

Matt Brace

Cresco Building Service

521 2nd Ave SW

PO Box 88

Cresco IA 52136

563- 547- 2525

563- 547- 2256 FAX

641-220-4403 CELL

matt@crescobuildingservice.com



SKYLINE CONSTRUCTION, INC.

900 Montgomery Street, P.O. Box 127

Decorah, IA 52101

(563) 382-2933

CHANGE ORDER #3

Cresco Building Service
New Hampton CSD High School Improvements
New Hampton, IA
June 13, 2018

NO.	ITEM DESCRIPTION	QUANTITY	UNIT	UNIT PRICE	BID AMOUNT
1	Remove Top of Existing Intake Structure and Replace with Solid Top (includes manhole frame and casting)	1	EA	\$ 2,500.00	\$ 2,500.00
2	Overhead, Excavation, Backfill, Misc., Tools, Pumps, etc.	1	LS	\$ 675.00	\$ 675.00
TOTAL = \$					3,175.00

- *Bonds and Dues are not included in above pricing.
- *Sales Tax and Aggregate Tax is not included in above pricing.
- *Final quantities are based on field measurements and load tickets.
- *Construction survey is not included in above pricing.
- *All items are tied.
- *No incidental seeding is included.
- *Quotes must be accepted within 30 Days of bid date.
- *Return signed quote and preliminary project schedule to Jeremy Brill (email: jsb@brueningrock.com or fax: (563) 382-8375).

Are Doc Express Reports required for this project? Yes No

Seller: Skyline Construction, Inc.

Jesse Delaney

Signature

6-18-18

Date

Buyer:

Print Name and Title of Authorized Buyers Rep.

Signature

Date

Signature by Buyer Acknowledges Acceptance of Quotation

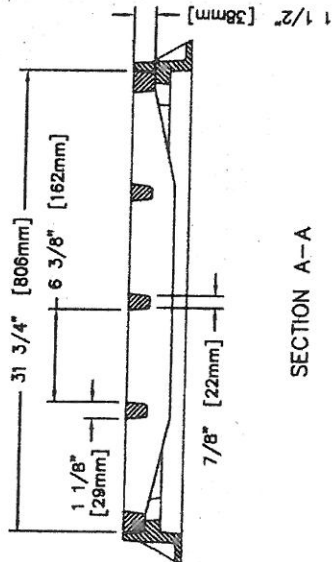
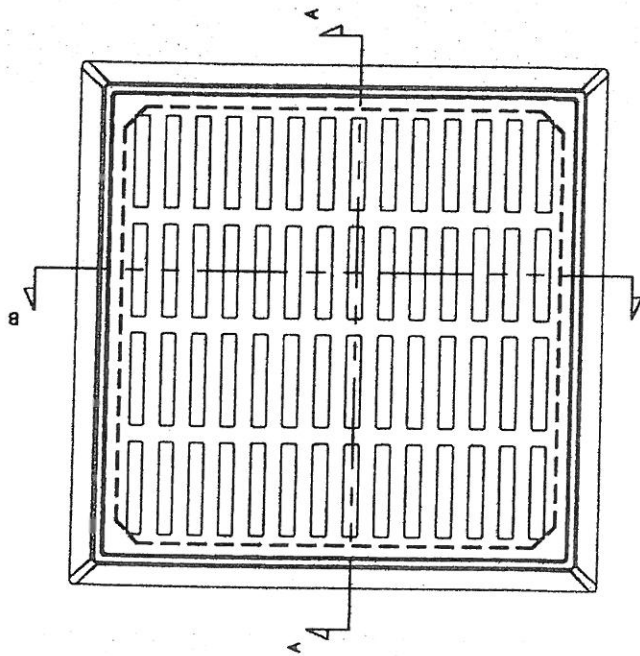

SECTION A-A

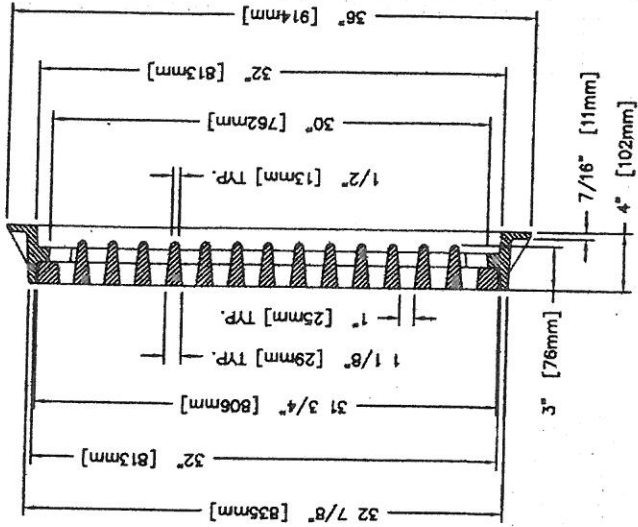

SECTION B-B

NOTE: ALL DIMENSIONS SHOWN ARE IN ENGLISH AND [METRIC]
 COMPONENT NO'S: FRAME 1878-202B, GRATE 1878-006B
 MATERIAL: CAST GRAY IRON ASTM A-48, CLASS 35B
 FINISH: NO PAINT

WEIGHT: FRAME 128# GRATE 341#

DR.	KMH	SCALE	TITLE
CHK.		1 : 8	R-1878-A9G
APP.			FRAME AND GRATE
DATE	12-04-98		

NEENAH
 FOUNDRY COMPANY
 NEENAH, WISCONSIN 54956

NF-1878 432 B

Approved

CRESCO BUILDING SERVICE INC.

GENERAL CONTRACTOR
CONSTRUCTION MANAGEMENT

521 2nd Avenue SW; P.O. Box 88
Cresco, IA 52136

Phone 563.547.2525 - Fax 563-547-2256

E-mail: matt@crescobuildingservice.biz

Website: www.crescobuildingservice.com



Authorized Dealer of Varco Pruden Pre-Engineered Steel Buildings

Change Order Request

Relating To:

COR GC #12 Alcove 601

(RFI #15)

DATE:

PROJECT: New Hampton CSD Middle/High School Additions

OWNER: New Hampton Community School District

ARCHITECT: Purdy & Slack (Dean Mitchell)

Installation of new steel lintel for joist bearing

Materials= \$725 Lintel Primed

Seedorff Masonry= \$540

Temp shoring, installation of beam= \$675

Subtotal=\$1940

OH&P= \$291

Total= \$2,231

needed for
load bearing
wall

Matt Brace

matt@crescobuildingservice.biz

641-220-4403 Cell

563-547-2525 Office



Please update my email contact info: matt@crescobuildingservice.biz

Approved - per Fire Marshal Requirement

CRESCO BUILDING SERVICE INC.

GENERAL CONTRACTOR
CONSTRUCTION MANAGEMENT

521 2nd Avenue SW; P.O. Box 88
Cresco, IA 52136

Phone 563.547.2525 - Fax 563-547-2256

E-mail: matt@crescobuildingservice.biz

Website: www.crescobuildingservice.com



Authorized Dealer of Varco Pruden Pre-Engineered Steel Buildings

Change Order Request

Relating To:
COR GC #13
Corridor #702 Ceiling

DATE: 8-16-18

PROJECT: New Hampton CSD Middle/High School Additions

OWNER: New Hampton Community School District

ARCHITECT: Purdy & Slack (Dean Mitchell)

6" 16 ga metal stud with Type X Finished drywall ceiling. Fire rated plywood on top side in Corridor #702. This replaces RFI #16 as discussed between Dave Bourassa & Dean Mitchell on site.

Prowall= \$5159
Thorne Painting \$250
Ceiling Pro Plus (Credit for Acoustical Ceiling Grid & Tile)= -\$406

Subtotal= \$5003

OH&P= \$751

Total= \$5754

Matt Brace
matt@crescobuildingservice.biz
641-220-4403 Cell
563-547-2525 Office



Please update my email contact info: matt@crescobuildingservice.biz

Fire Marshal Required

CRESCO BUILDING SERVICE INC.

GENERAL CONTRACTOR
CONSTRUCTION MANAGEMENT

521 2nd Avenue SW; P.O. Box 88

Cresco, IA 52136

Phone 563.547.2525 - Fax 563-547-2256

E-mail: matt@crescobuildingservice.biz

Website: www.crescobuildingservice.com



Authorized Dealer of Varco Pruden Pre-Engineered Steel Buildings

Change Proposal Request

Relating To:

Door Opening/HDW Changes

DATE: 6-18-18

PROJECT: New Hampton CSD Middle/High School Additions

OWNER: New Hampton Community School District

ARCHITECT: Purdy & Slack (Dean Mitchell)

Reviewed Submittal Changes & RFI #12

Door # 130,130A,136,137,140,141,306,306A,324,325,327,328 – Change HW 1 to HW 34 = **\$4,312.00M, \$240L**

Door # 305 – Change Elevation Type 22 to Type 21 = **\$201.00M**

Door # 309A – Change 3070 5 3/4" HW16 to 3470 9" HW16.2 = **\$96.00M**

Door # 416 – Change PR 3'0" to PR 4'0" & change HW14 to 14.2 = **\$965.00M**

Door #417 – Change to 60 min = **\$164.00M**

Door #436 – Change HW Set 3 to HW Set 34 = **\$412.00M, \$20L**

ADD 11 Overhead Stops = **\$1,034.00M, \$440L**

SUBTOTAL=\$7,884

OH & P= \$1,182

TOTAL= \$9,066

Matt Brace

matt@crescobuildingservice.biz

641-220-4403 Cell

563-547-2525 Office



Please update my email contact info: matt@crescobuildingservice.biz